

OPUS HE 24-4.5 R7U F
OPUS HE 48-6.0 R7U F
OPUS HE 60-6.0 R7U F
OPUS HE 110-6.0 R7U F
OPUS HE 125-6.0 R7U F
OPUS HE 220-6.0 R7U F



Product Description

OPUS HE power systems are robust, free convection cooled, N+1 redundant backup power solutions for critical infrastructure applications such as transmission and distribution substations, process industries, railway signalling and substations and telecommunications.

OPUS HE DC power systems consist of MHE rectifiers, VIDi+ controllers, Connections for mains and battery and load distribution. System is configurable to match with requirements of the application.

19" 7U Rack delivers maximum 6 kW output power at 48, 60, 110, 125 and 220 VDC and 4.5 kW at 24 VDC output. 19" 7U Racks include slots for maximum 3 rectifier modules, battery breakers and shunt for one string and bulk DC load output. Wall mounting, IP21 cover kit, temperature sensor, battery block voltage monitoring and BLVD are options. Master-slave set-up can be used to increase power higher than 6kW.

Features

- Efficiency up to 97%
- Convection cooling – no fans
- Outputs 24, 48, 60, 110, 125, 220 VDC
- 6.0 kW output power, 24VDC 4.5kW
- Building block rack for cabinet integration, Master-Slave 2 x 7U rack – power up to 16kW
- VIDi+ I/O controller, local and remote interfaces 12 x relays, Ethernet, Modbus, IEC61850, SNMP, RS-232
- Flexible design with full front cabling
- Options: Wall mounting and IP21 kit, BLVD contactor, battery block voltage monitoring
- Safety:
 - Rack: EN61439-1, EN61439-2
 - Low voltage switchgear controlgear assemblies
 - Rectifiers: EN 62368-1, EN 50124-1 rail
- EMC:
 - Rack: EN61439-1, EN61439-2
 - Rectifiers: EN 61000-6-1 / -2 / -3 / -4 / -5
 - EN 50121-4 rail, ETSI EN 300386 (48/60V)

Technical Specifications

General construction		Environment and standards	
Cooling	Natural convection	Temp. range	-25 ... +60°C, see derating, Start-up at -40°C
Protection	IP 20, Option IP21	Humidity max	95% relative humidity, non-condensing
Controller user interface	Display and local control in front panel	Altitude	Max 3km, full power up to 2km above sea level Derating 2% per 100 m between 2-3km
Connections	Behind front panel	Safety	Rack: EN61439-1, EN61439-2 Rectifiers: EN 62368-1, EN 50124-1 rail
Colour	Frame RAL 7024	EMC	Rack: EN61439-1, EN61439-2 Rectifiers: EN61000-6-1 / -2 / -3 / -4 Generic EN61000-6-5 Utility, surge level 2 EN 50121-4 Rail, ETSI EN 300 386 (48/60V)
Dimensions & weight	Height 7U (350 mm) Width 19" (482 mm) Depth 503 mm Weight 15 kg w/o rectifiers		

AC Input	OPUS HE 24-4.5 R7U F	OPUS HE 48-6.0 R7U F	OPUS HE 60-6.0 R7U F	OPUS HE 110-6.0 R7U F	OPUS HE 125-6.0 R7U F	OPUS HE 220-6.0 R7U F
AC connection	TN-S system, 3W + N + PE, (3-phases, neutral and protective earth wires)					
Nominal input	220-240 VAC / 3 x 380-415 VAC (TN-S system) <i>Options: 1-phase supply 100-250VAC, 3-phase Delta/IT supply 3 x 173-250VAC</i>					
Input range	Max range: 85 – 300 VAC / 3 x 147–528 VAC Rated full power range: 180 – 275 VAC / 3 x 312–476 VAC (TN-S system) See derating curves below, 1200W per rectifier at 120VAC / 3 x 208VAC Temporary high voltage range 275 - 300VAC / 3 x 476 - 528VAC, continuous supply not recommended					
Input frequency	Rated 45 - 66 Hz, reduced power at 35 - 45 Hz. Shut down at 35 Hz					
Nominal current	8A @ 220/380V	11A @ 220/380VAC				
Maximum phase current	12,5A @ 85-130V	12,5A @ 85-180VAC				
Recommended mains fuse	3 x 25 A (TN-S)					
Main Switch	20A, 4-pole (L1-L2-L3-N)					
Rectifier input protection	MCB C16A / rectifier module					

DC Output	OPUS HE 24-4.5 R7U F	OPUS HE 48-6.0 R7U F	OPUS HE 60-6.0 R7U F	OPUS HE 110-6.0 R7U F	OPUS HE 125-6.0 R7U F	OPUS HE 220-6.0 R7U F
Grounding	2-pole, floating					
Nominal voltage	24 VDC	48 VDC	60 VDC	108 VDC	120 VDC	216 VDC
Voltage factory setting	27.24 VDC	54.48 VDC	68.10 VDC	122.58 VDC	136.20 VDC	245.16 VDC
Voltage range	21-33 VDC	42-59 VDC	51-72 VDC	90-150 VDC	100-160 VDC	178-280 VDC
Quantity of rectifiers	Max 3 pcs					
Max current	187.5A @ 24V	125A @ 48V	100A @ 60V	55.5A @ 108V	50A @ 120V	27.8A @ 216V
Max Power	Max 4.5kW *)	Max 6kW	Max 6kW	Max 6kW	Max 6kW	Max 6kW
Static voltage regulation	± 1.5 % @ rack terminals (load, line, temp)			± 1 % @ rack terminals (load, line, temp)		
Rectifier output protection	MCB C63A	MCB C50A	MCB C40A	MCB C20A	MCB C20A	MCB C10A

*) Battery MCB D125A, max battery current 125A

Battery connection	OPUS HE 24-4.5 R7U F	OPUS HE 48-6.0 R7U F	OPUS HE 60-6.0 R7U F	OPUS HE 110-6.0 R7U F	OPUS HE 125-6.0 R7U F	OPUS HE 220-6.0 R7U F
Protective device	MCB D125A 2-pole + aux	MCB D125A 2-pole + aux	MCB D125A 2-pole + aux	MCB D63A 2-pole + aux	MCB D63A 2-pole + aux	MCB D63A 2-pole + aux

Connection terminals	
Mains terminal	Q1 Main switch, 10 mm ² screw terminals, L1-L2-L3-N-PE
DC output	Bulk output X2, screw terminals 35 mm ²
Battery	MCB screw terminals, 1.5...35 mm ² flexible cable, 1...50 mm ² rigid cable
Alarms, Inputs	Configurable relay alarms 4 pcs (option up to 12), Spring terminals 0.75mm ² ... 1.5mm ² cable Configurable alarm/temp. inputs 4 pcs (option up to 12), Spring terminals 0.75mm ² ... 1.5mm ² cable

Derating curves

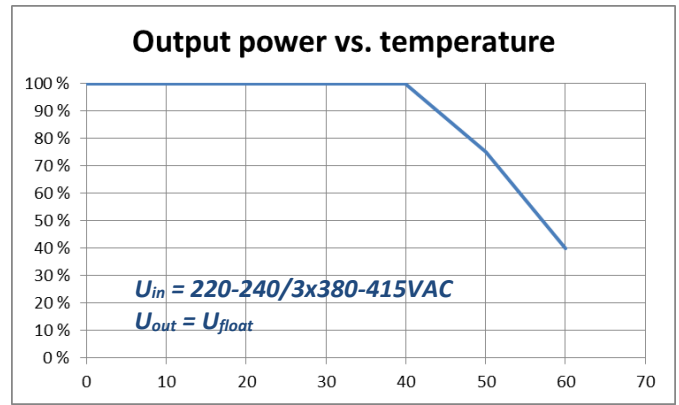
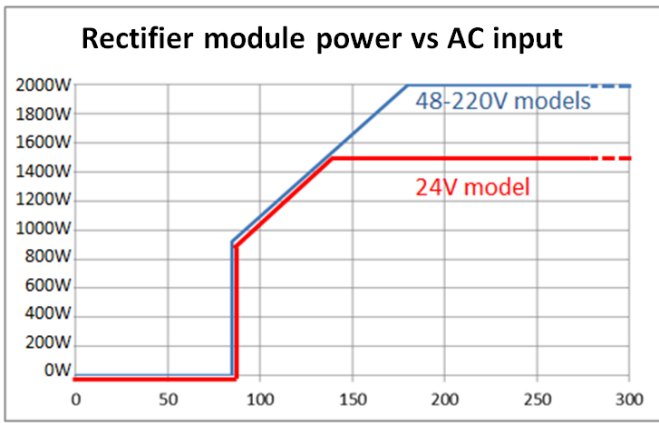

Block Diagram, 2-pole floating systems

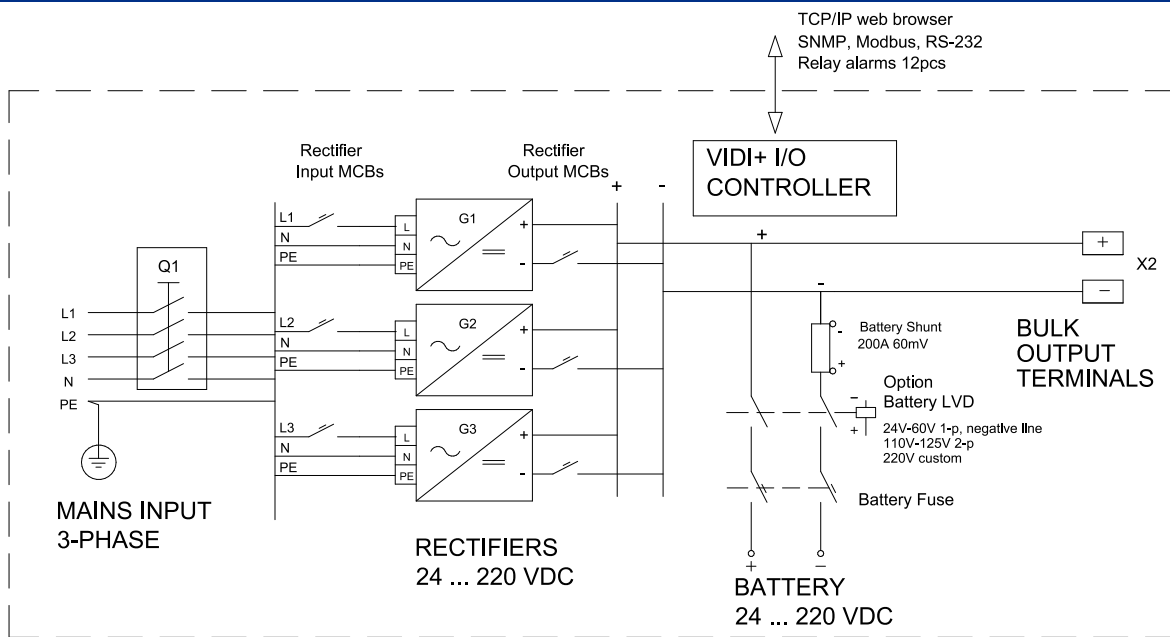

Block Diagram, Master-Slave connection up to 16kW

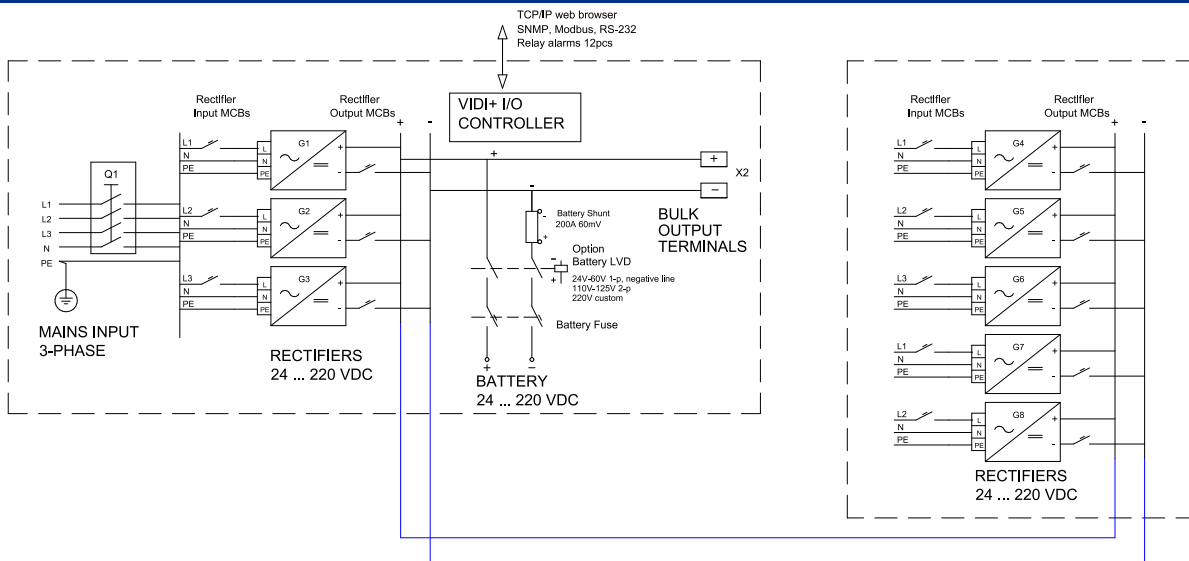

Layout drawings

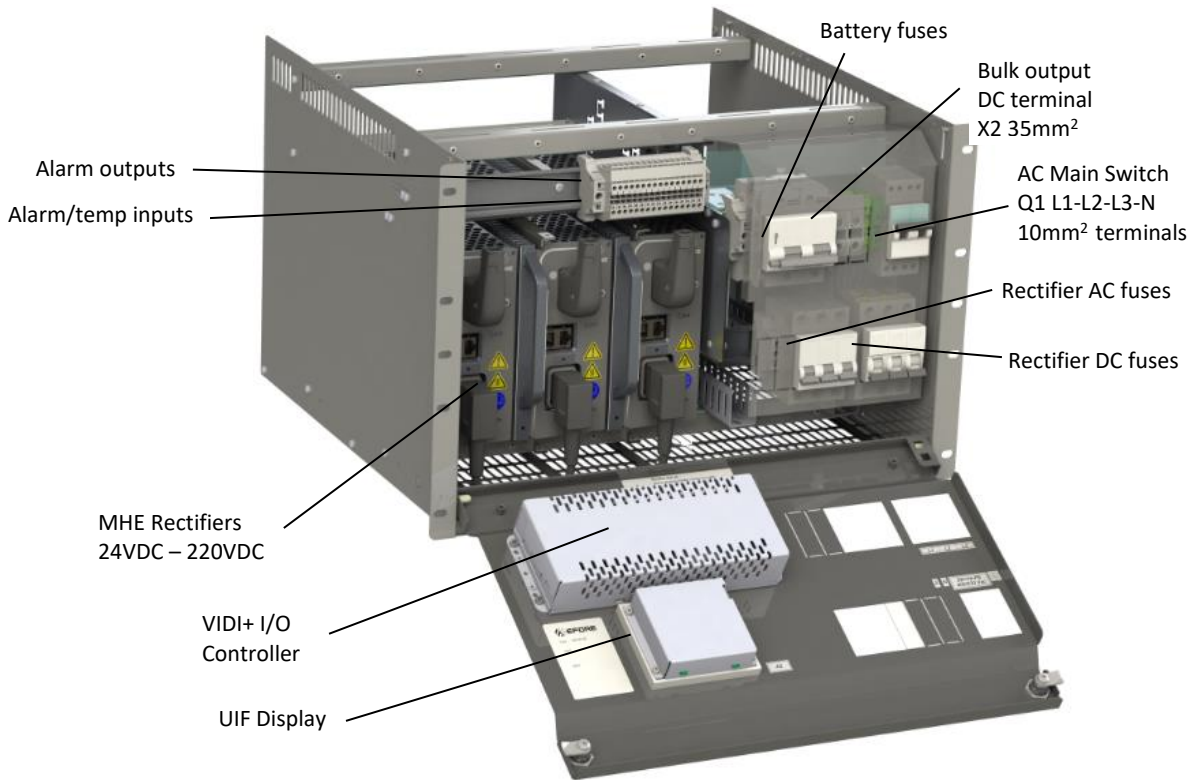

19" 7U Master-Slave rack to increase power up to 16kW, mechanical rack only – no wiring done in slave rack



Systems, Description	Order number
OPUS HE R7U SLAVE 5 x MHE	9220X0015100

Order Information

Systems, Description	Order number	Voltage / Current	Rectifiers	Order number
OPUS HE 24-4.5 R7U F	9220X0011282	24VDC / 62.5A – 187.5A	MHE24-1500	92I280
OPUS HE 48-6.0 R7U F	9220X0011288	48VDC / 41.7A – 125A	MHE48-2000	92I160
OPUS HE 60-6.0 R7U F	9220X0014569	60VDC / 33.3A – 100A	MHE60-2000	92I290
OPUS HE 110-6.0 R7U F	9220X0011271	110V / 18.5A – 55.5A	MHE110-2000	92I250
OPUS HE 125-6.0 R7U F	9220X0014574	125V / 16.7A – 50A	MHE125-2000	92I260
OPUS HE 220-6.0 R7U F	9220X0011277	220V / 9.3A – 27.8A	MHE220-2000	92I270

Controllers, Description	Order number	Options, Description	Order number
VID+ I/O System controller	94G910	VIDI-BM Block voltage monitoring	9040X0002338

Options, Description	Order number	Options, Description	Order number
Temperature Sensor	94M268	BLVD 24V 200A 1-P R 7U P	8320X0005019
Wall mounting and IP21 kit 7U	8320X0004982	BLVD 48/60V 200A 1-P R 7U P	8320X0005017
		BLVD 110/125V 100A 2-P R 7U F	8320X0004952