

HWS 1500 Series Instruction Manual

BEFORE USING THE POWER SUPPLY UNIT

Be sure to read the following precautions thoroughly before using this power supply unit.

Pay attention to all warnings and cautions before using the unit. Incorrect usage could lead to an electrical shock, damage to the unit or a fire hazard.

⚠ WARNING

- Do not make unauthorized changes to power supply unit, otherwise you may have electric shock and void your warranty.
- Do not touch the internal components; they may have high voltage or high temperature. You may get electrical shock or burned.
- When the unit is operating, keep your hands and face away from it; an accident may injure you.
- Do not use unit under unusual condition such as emission of smoke or abnormal smell and sound etc. It might cause fire and electric shock.

In such case, please contact us; do not repair by yourself, as it is dangerous for the user.

- Do not drop or insert anything into unit. It might cause failure and fire, when using the unit under such condition.
- Do not operate these units at the condition of condensation. It may cause fire and electric shock.
- This power supply has a possibility that hazardous voltage may occur in output terminal depending on failure mode.
- The outputs of these products must be earthed in the end use equipment to maintain SELV

If the outputs are not earthed, they must be considered hazardous and must not be made user accessible.

⚠ CAUTION

- This power supply is primarily designed and manufactured to use and enclose in other equipment.
- This power supply unit has a built-in fan for air-cooling. Do not block air intake and exhaust. It might cause fire.
- Input voltage, Output current, Output power, ambient temperature and ambient humidity should be used within specifications, otherwise the unit will be damaged.
- The unit might be broken down by accident or unexpected situation. For application equipment, which requires very high reliability (nuclear related equipment, traffic control equipment, medical equipment, etc.), please provide fail safety function in the equipment.
- Do not make an improper wiring to input and output terminals. It may cause damage
- Do not use in environment such as strong electromagnetic field, corrosive gas etc, or any environment where conductive foreign substance may enter
- Do not operate and store this unit at the condition of condensation. In such case, waterproof treatment is necessary.
- Do not operate this unit after it falls down.
- The output voltage of this power supply unit is considered to be a hazardous energy level (The voltage is 2V or more and the electric power is 240VA or more), prevention from direct contact with voltage output is highly necessary. While installing or servicing this power supply unit, avoid dropping tools by mistake or direct contact with voltage output. This might cause an electrical shock.

While repairing this power supply unit, the AC input power must be switch off and the I/O terminal voltage should be less than the safety level.

DWG NO. : DA006-04-01		
APPD	CHK	DWG
<i>K. Nakita</i>	<i>K. Asami</i>	<i>T. Muto</i>
<i>21. Sep. 2005</i>	<i>20 Sep. 2005</i>	<i>20. Sep. 2005</i>

1. Model name identification method

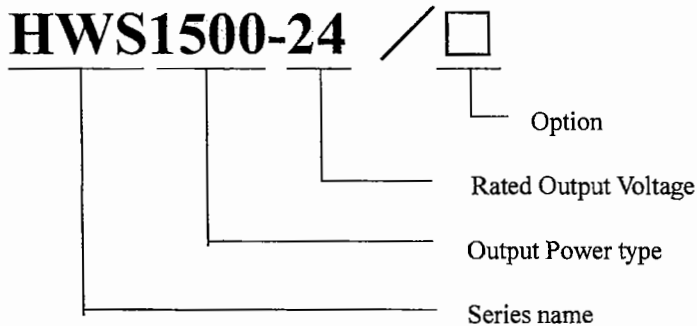

2. Terminal Explanation

Please pay extra attention to the wiring. Incorrect connection will damage the power supply.

- When connecting input and output wiring, input AC-Line should be off.
- Input wiring and output wiring shall be separated, otherwise noise susceptibility of power supply unit will be weak.
- The protective earth (PE) must be connected to the instrument chassis and the chassis of this power supply unit .
- Remote sensing lines shall be twisted or use the shielded wire.
- Remote ON/OFF control lines shall be twisted or use the shielded wire.

2-1. Front Panel Explanation

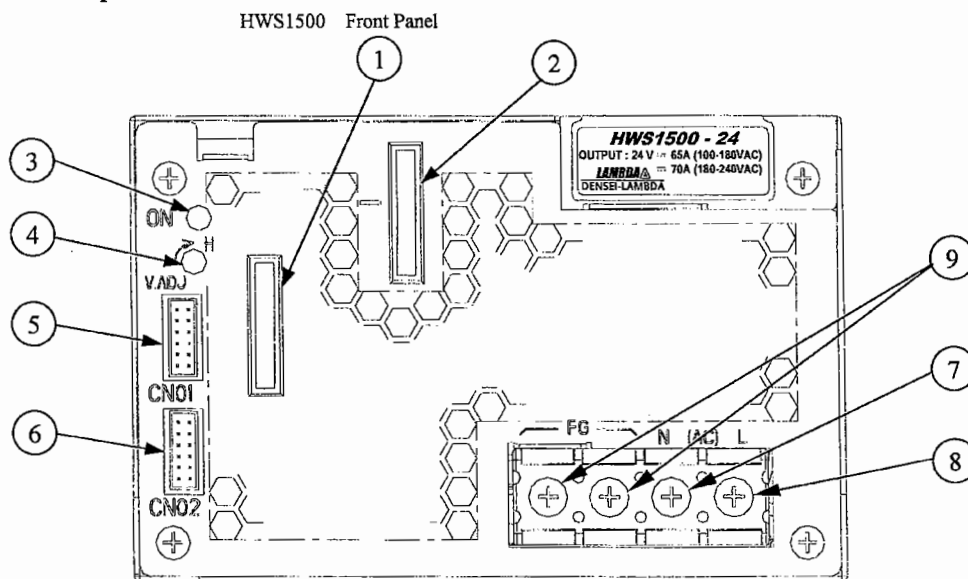

- ① + : + Output terminal
- ② - : - Output terminal
- ③ ON : Output (Power On) indication green LED
(The indicator turns on when the power supply output is in normal operating condition.)
- ④ V.ADJ :Output voltage adjust trimmer (The output voltage rises when trimmer is turned clockwise.)
- ⑤ CN01: } Remote sensing, ON/OFF control signal, Current balance signal,
- ⑥ CN02: } Output voltage external control signal and Power fail signal output connector.
- ⑦ N : AC input terminal N : Neutral line
- ⑧ L : AC input terminal L : Live Line (Fuse in line)
- ⑨ FG :Function Ground terminal (Frame ground)

2-2. CN01, CN02 Connector pin configuration and Function

CN01, CN02 pin configuration and function are the same.

They are connected to each other in this power supply unit.

When the pin of CN01 side is shorted the same function pins of CN2 side are shorted.

Please note that the function cannot be separately set with CN01 and CN02.

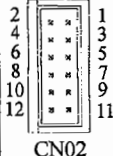
	Pin No.	Configuration	Function
 CN01	1	+V	Connected to + Output terminal in this Power supply unit. (+V terminal can not supply load current.)
	2	+S	Remote sensing terminal for + output (For remote sensing function, which compensates for line drop between power supply terminals and load terminals. Connect to +V terminal when remote sensing function is unnecessary)
	3	-V	Connected to - Output terminal in this Power supply unit. (-V terminal can not supply load current)
	4	-S	Remote sensing terminal for - output (For remote sensing function, which compensates for line drop between power supply terminals and load terminals. Connect to -V terminal when remote sensing function is unnecessary)
 CN02	5	PC	Current balance terminal (For output current balancing in parallel operation.)
	6	COM	Ground for PC and PV signal.
	7	PV	Output voltage external control terminal (For power supply output voltage control with an external voltage Connect it with the terminal REF when PV function is unnecessary.)
	8	REF	Reference Voltage terminal for Output voltage control (REF and PV are connected when shipping.)
	9	CNT	Remote ON/OFF control terminal (When the CNI is pulled to TTL low, the power supply turns on.)
	10	TOG	Ground for CNT and PF signal.
	11	PF	Power fail signal output terminal (As the output voltage drops, FAN stops and AC input voltage down, open collector output, "Power Fail" signal will output "High".)
	12	TOG	Ground for CNT and PF signal.

CN01, CN02 are connected in this power supply unit as follows.

CN01

CN02

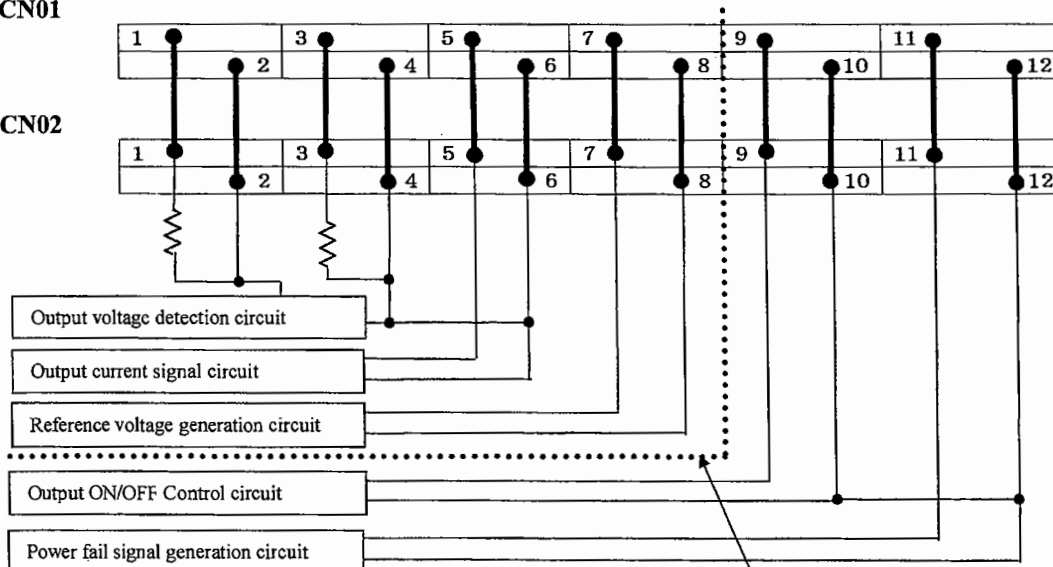

※Output ON/OFF control circuit and the Power fail signal circuit are insulated with other circuits in the power supply. (Insulating voltage AC100V)

2-3. Basic Connection (Local sensing)

- ① Connect "+S" terminal to "+V" terminal and "-S" terminal to "-V" terminal with sensing wires.
 - ② Connect "CNT" terminal to "TOG" terminal with wire.
 - ③ Connect "PV" terminal to "REF" terminal with wire.
- ※ Please use attachment connector for each connection.
 - ※ In the following cases, the output is shut down.
When CNT and TOG is opened.
When PV and REF is opened.

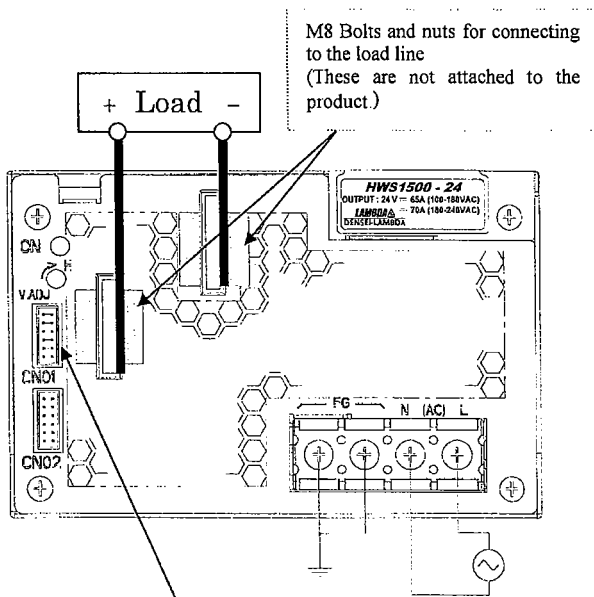

Connector : (JST) S12B-PHDSS

Attached connector when shipping

- Housing : (JST) PHDR-12VS
 - Contact : (JST) SPHD-001T-P0.5
- 1~2, 3~4, 7~8, 9~10 are shorted

2-4. Remote sensing required

- ① Connect "+S" terminal to "+" terminal of load with sensing wire
 - ② Connect "-S" terminal to "-" terminal of load with sensing wires.
 - ③ Connect "CNT" terminal to "TOG" terminal with wire.
 - ④ Connect "PV" terminal to "REF" terminal with wire.
- ※ The accuracy of the output voltage will deteriorate when the sensing terminals are opened.
 - ※ In the following cases, the output is shut down.
When CNT and TOG is opened.
When PV and REF is opened.

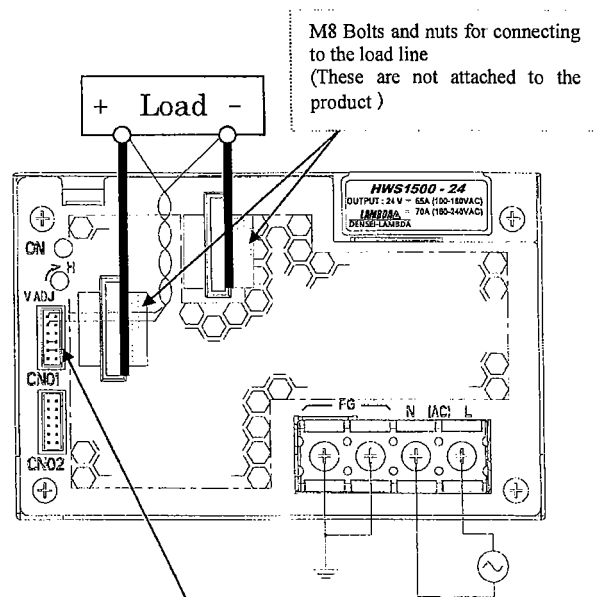

Connector : (JST) S12B-PHDSS

Remove standard attached connector, and use the harness made by the customer.

- Housing : (JST) PHDR-12VS
 - Contact : (JST) SPHD-001T-P0.5
- 2~"+ of load, 4~"- of load should be connected
7~8, 9~10 : should be shorted

* Please use wire for contact and crimping tool specified by maker.

Attached connector when shipping

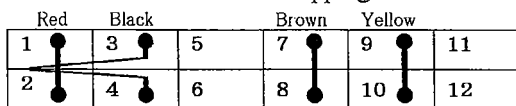

Connecting circuit with CN01 or CN02 connector

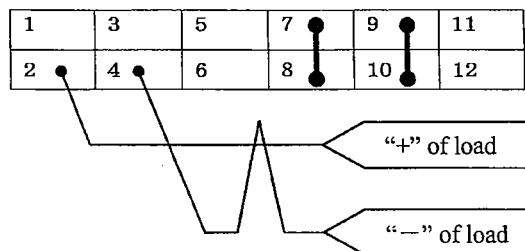

2-5. Remote ON/OFF control required

- ① Remove standard attached connector, and use the harness made by the customer and connect external signal to between CNT and TOG terminal.
- ② "TOG" terminal is ground for "CNT" terminal.
In case this function is not used, please short between CNT and TOG terminal.

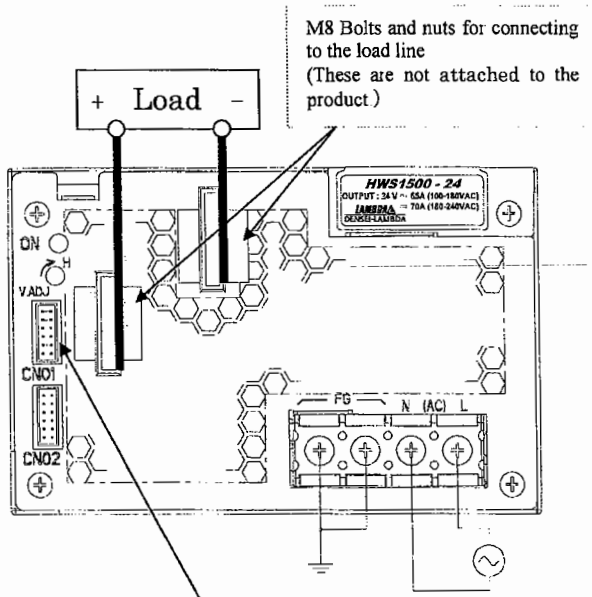

Connector : (JST) S12B-PHDSS

Remove standard attached connector, and use the harness made by the customer

- Housing : (JST) PHDR-12VS
 - Contact : (JST) SPHD-001T-P0.5
 - 1~2, 3~4, 7~8 : should be shorted
 - 9 : CNT
Should be connected to ON/OFF control signal.
 - 10 : TOG
Should be connected to Signal Ground.
- * Please use wire for contact and crimping tool specified by maker.

Connecting circuit with CN01 or CN02 connector

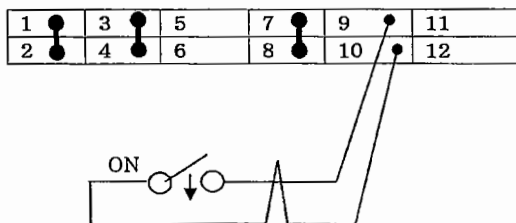

2-6. PF signal output required

- ① PF signal is an open collector output, therefore PF signal outputs is shown in circuit below.
- ② "TOG" terminal is ground for "PF" terminal.

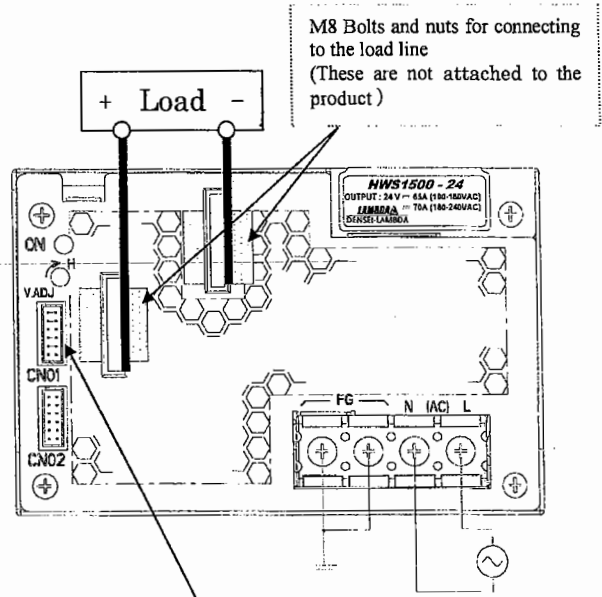

Connector : (JST) S12B-PHDSS

Remove standard attached connector, and use the harness made by the customer.

- Housing : (JST) PHDR-12VS
 - Contact : (JST) SPHD-001T-P0.5
 - 1~2, 3~4, 7~8, 9~10 : should be shorted.
 - 11 : PF
Should be connected to PF signal output
 - 12 : TOG
Should be connected to Signal Ground.
- * Please use wire for contact and crimping tool specified by maker.

Connecting circuit with CN01 or CN02 connector

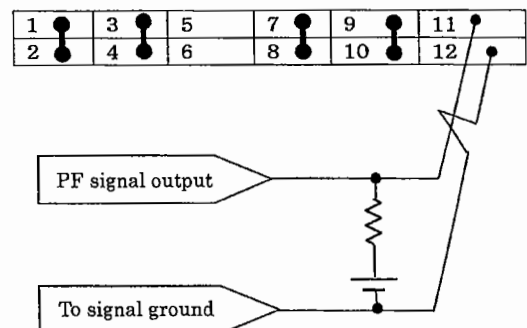

3. Functions and Precautions

3-1. Input Voltage Range

Input voltage range is single phase 85 ~ 265VAC (47 ~ 63Hz). Input voltage, which is out of specification, may cause unit damage. Rated input voltage range fix during safety standard application is from 100V to 240VAC (50/60Hz). While applying input voltage from 85Vac to 90Vac, output load current derating is required.

3-2. Output Voltage Range

Output voltage is set to the rated value at shipping. V.ADJ trimmer on the front panel side is use to adjust the output voltage within the range specified. Output voltage trimming range is within -20% ~ +20% of the rated output voltage (48V Output Model: -20% ~ +10%). Turn the trimmer clockwise to increase output voltage. Take note when the output voltage is increased excessively over voltage protection (OVP) function may trigger and output voltage will shut down.

Use the output power of the power supply below the rated output power value when you raise the output voltage.

3-3. Over Voltage Protection (OVP)

The OVP function (Inverter shut down method, manual reset type) is provided. OVP function operates within 125-145% of the rated DC output voltage value (48V type: 115-135%), and the output will be shut down when OVP function triggers. When OVP function operates, the input power is cut off for a few minutes, and then power is re-input or remote ON/OFF control signal shall be input for recovery of the output. OVP value is fixed and can not be adjusted.

3-4. Over Current Protection (OCP)

The OCP function (Constant current limiting, Time delay shutdown type) is provided. OCP function operates when the output current exceeds 105% of maximum DC output current specification and the over current or short circuit condition continues 5-second or more, the output will be shut down. When the OCP is triggered, the input power is cut off for a few minutes, and then power is re-input or remote ON/OFF control signal should be input for recovery of the output. The OCP setting is fixed and not to be adjusted externally.

3-5. Over Temperature Protection (OTP)

Over temperature protection function (manual reset type) is provided. When ambient or internal temperature rises abnormally, OTP will shut down the output. When OTP is triggered, input power is cut off and allow sufficient cooling to reset the OTP function. Then power is re-input or remote ON/OFF control signal should be input for recovery of the output.

3-6. Low Output Detection Circuit (PF)

Low output voltage detection circuit is provided. Power Fail signal (PF signal) will output when output voltage decrease by either the drop or brown out of the input voltage or OCP, OVP and OTP function operation. PF signal will turn "High" level to indicate the abnormal status of the power supply when the output voltage decrease to 80% of the output voltage setting value. The PF signal circuit is insulated from the power supply input and output circuit and it is an open collector. TOG terminal is ground for PF terminal.

When the Built-in Fan Motor of this power supply unit stops, PF signal will turn to "H" and the output power will shut down. The Built-in Fan Motor is a component with lifetime. We recommend a periodic replacement. Please contact our sales office. Replacement is at customer's expenses.

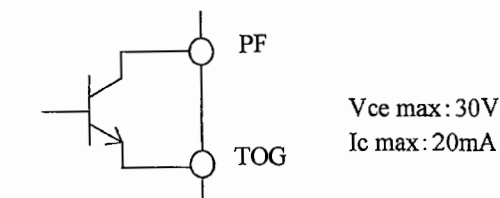

3-7. Remote Sensing (+S, -S terminal)

Remote sensing function is provided to compensate for voltage drop across the wiring from the power supply output terminals to the load input terminals. Connect "+S" terminal to "+" terminal of the load and "-S" terminal to "-" terminal of the load with sensing wires. The total line voltage drop (+ side line and - side line) shall be less than 0.3V. In case that sensing line is too long, it is necessary to put an electrolytic capacitor across the load terminals.

Please take note that the electrolytic capacitor has generation of heat etc. done by the ripple current depending on connected load. Therefore, the electrolytic capacitor must have a ripple current allowance higher than the output ripple current. If CN01 (or CN02) is in use, terminal +S, -S for CN02 (or CN01) must be in open condition.

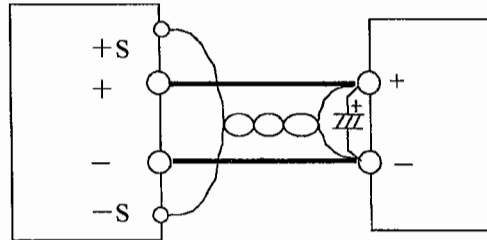

When the function of remote sensing is not in used, connect +S terminal to +V terminal, and -S terminal to -V terminal by the attachment connector.

If remote sensing terminals are opened, the stability and the accuracy of the output deteriorate. Therefore, terminal +S, -S must be connected.

3-8. Remote ON/OFF Control

Remote ON/OFF control is provided. Output can be remotely switch ON and OFF by using CNT terminal and TOG terminal even though input is connected. The output is turned to ON when TOG and CNT terminals are shorted and output is turned to OFF when these terminals are opened. When the function is not used, connect TOG and CNT terminals with short piece. The standards for this function are as follows. "TOG" terminal is ground for "CNT" terminal.

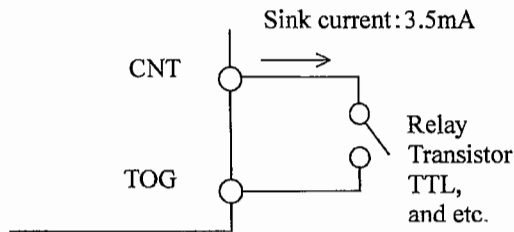

The Mode of control

CNT Level for TOG Terminal	Output	Built-in Fan Motor
Short or L (0~0.8V)	ON	Rotate
Open or H (2.4~12V)	OFF	Stop

- (1) TTL compatible. The maximum input voltage to CNT terminal is 12V, and the maximum allowable reverse voltage is -1V. The sink current of CNT terminal is 3.5mA.
- (2) Output ON/OFF control can be enable by a switch, relay or a transistor ON/OFF. When CNT terminal~TOG terminal is shorted power supply is turn ON, and when CNT terminal~TOG terminal is opened power supply is turn OFF.
- (3) Remote ON/OFF control circuit is isolated from the input and output circuit of power supply. It is possible to use it regardless of the positive and negative of the power supply output.

3-9. Output Ripple & Noise

Maximum ripple & noise value in specifications is measured according to measurement circuit specified by JEITA-RC9131A. When Load lines are longer, ripple & noise becomes larger. In this case, electrolytic capacitor, film capacitor, etc. might be necessary to use across the load terminal. The output ripple & noise cannot be measured accurately if the probe ground lead of oscilloscope is too long.

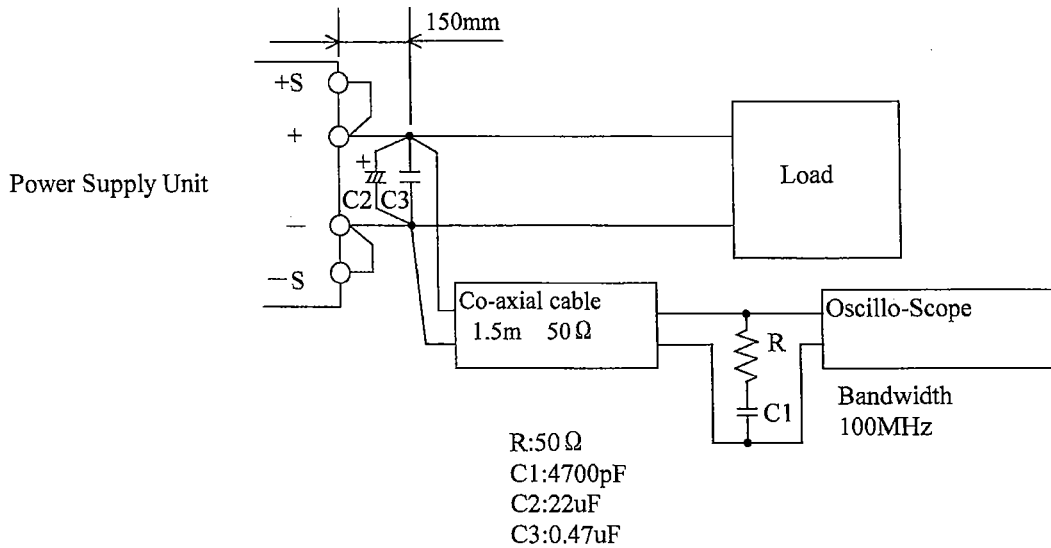

3-10. Series Operation

For series operation, either method (A) or (B) is possible.

There might be a step in the rise waveform during series operation.

Method (A)

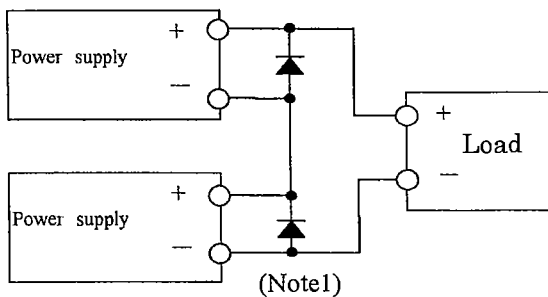

Method (B)

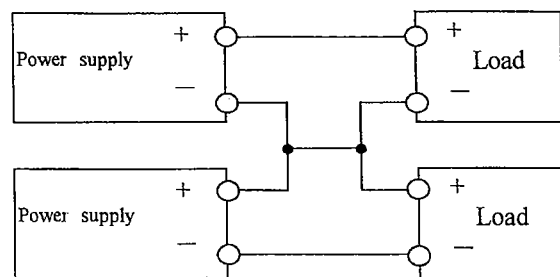

(Note1) Please connect a diode for by-pass when using method (A) of the series operation.

Please use the diode with rated forward current is equal or more than load current and that the rated maximum reverse voltage is higher than output voltage for each power supply.

3-11. Parallel Operation

Current balancing function is provided. Either of operations mode (A) or (B) is possible.

(A) To Increase the Output Current

Current balancing function activates by connecting PC-to-PC terminal and COM-to-COM terminal, and output current of each power supply is equivalently supplied to load. Wires to PC terminals shall be as short as possible, same length and twisted.

1. Adjust the output voltage of each power supply to be same value within 1% or 100mV, whichever is smaller.
2. Use same length and type of wires for all load lines.
3. Maximum value of output current in parallel is up to 80% of all paralleled models. The purpose of the current balancing function is the static power-up. Therefore the output voltage might decrease according to the condition of dynamic load. There might be a step in the rise waveform during parallel operation.
4. Up to 5 units can be connected in parallel.

(B) To Use as a Backup Power Supply

1. Set power supply output voltage higher by the forward voltage drop of diode.
2. Adjust the output voltage of each power supply to be same value.
3. Use within the specifications for output voltage and output power.

Method (A)

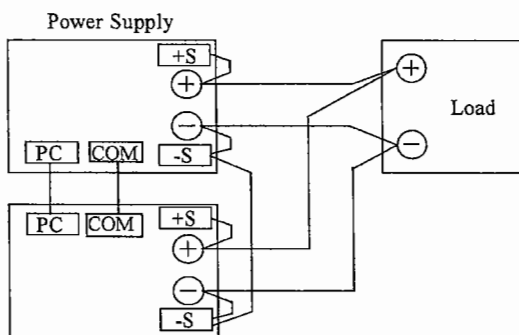

Method (B)

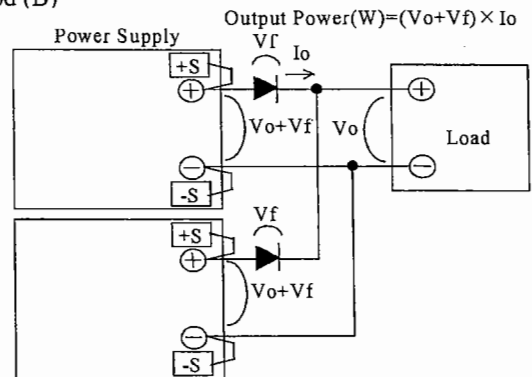

3-12. Isolation Test

Isolation resistance between output and FG (chassis) shall be more than 100MΩ at 500VDC and between output and CNT·PF shall be more than 10MΩ at 100VDC. For safety operation, voltage setting of DC isolation tester must be done before the test. Ensure that it is fully discharged after the test.

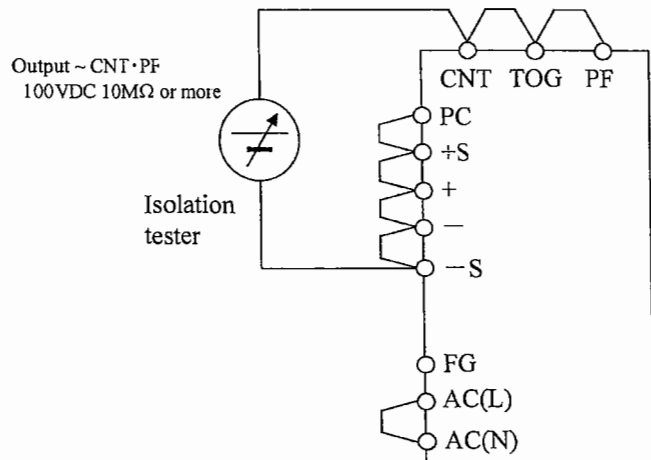
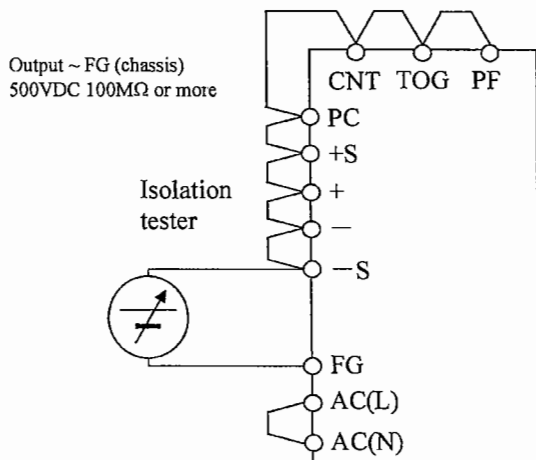

3-13. Withstand Voltage

This series is designed to withstand 3.0kVAC between input and output, 2.0kVAC between input and FG (chassis), 500VAC between output and FG (chassis), and 100VAC between output and CNT·PF terminal each for 1 minute. When testing withstand voltage, set current limit of withstand voltage test equipment at 20mA.

(Output-FG (chassis) : 300mA, Output- CNT·PF : 100mA).

The applied voltage must be gradually increased from zero to testing value and then gradually decreased for shut down. When timer is used, the power supply may be damaged by high impulse voltage at timer switch on and off. Connect input and output as follows. If output is left open during test, output voltage might appear momentarily.

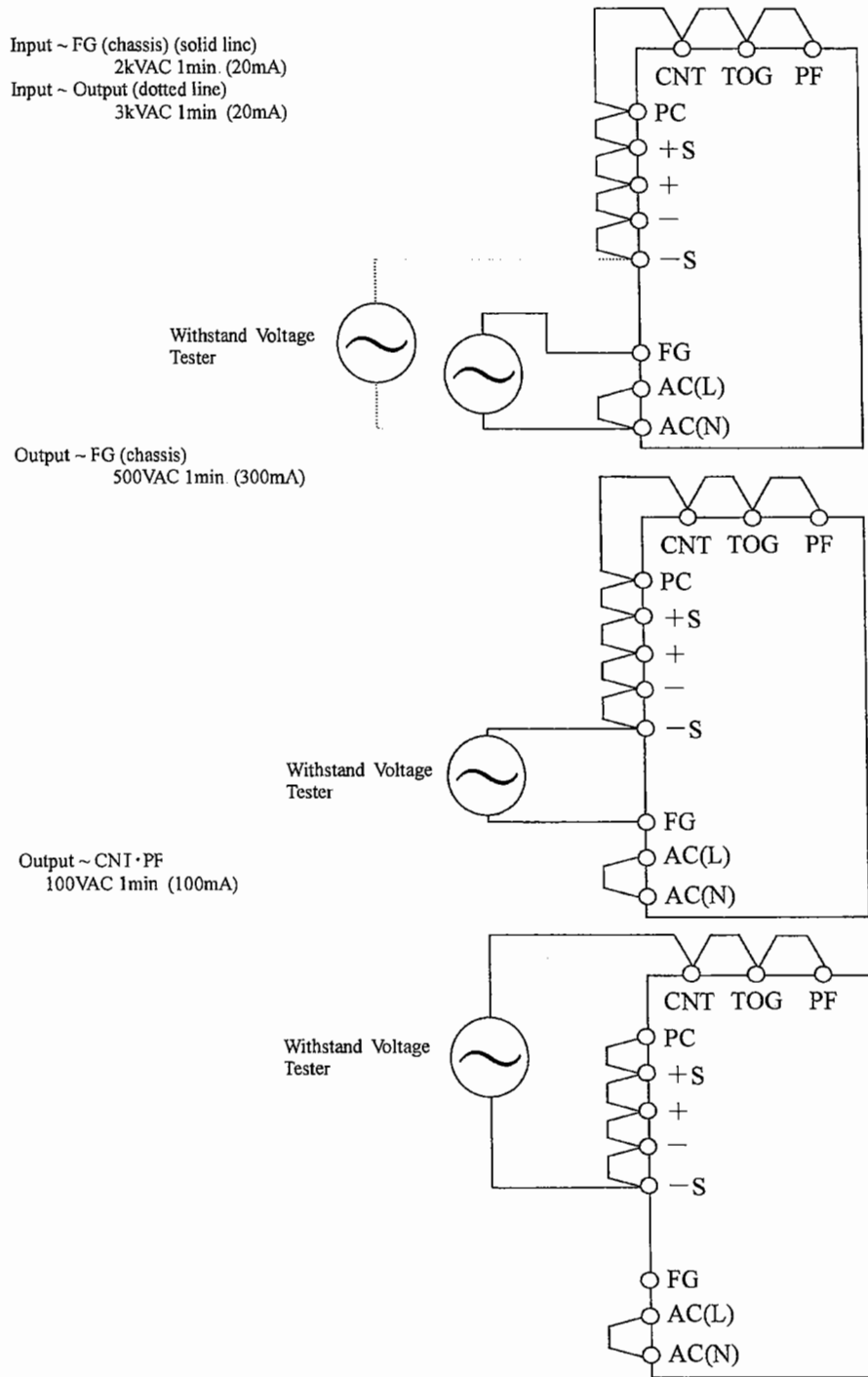

3-14. Output Voltage External Control (PV)

Output voltage external control function is provided. Output voltage can be varied by applying an external voltage (1 ~ 6V) to “PV” terminal and “COM” terminal. Note if an external voltage is not applied, there will be no output. Please consider the following characteristics below when operating the unit.

Connection Method

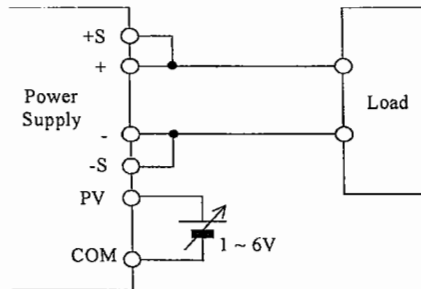

Output Voltage Linearity

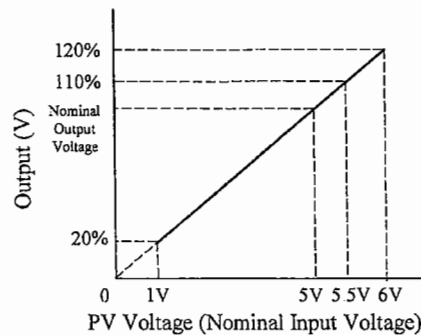

Note: Only as for the type of 48V output, the output voltage is used from 20% to 110% at the PV voltage is from 1V to 5.5V

Output Voltage Derating

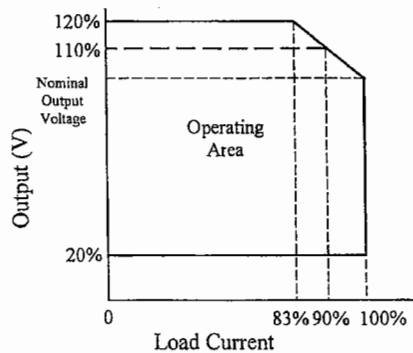

Note: Only as for the type of 48V output, the maximum output voltage is used up to 110% at 90% load current.

3-15. Output peak Current

For model HWS1500-24, please meet the following condition.

Reduce peak current value according to output derating as section 4-1.

Input voltage range	: AC180V~265V
Continuous Peak output time. (τ)	: Within 10 seconds
Peak output current (I_p)	: Within the rated peak output current
Average DC output current (I_m)	: Within the rated output current

$$I_m = \frac{I_p \times \tau}{T} \leq I_{av}$$

Duty : up to 35%

$$\text{Duty} = \frac{\tau}{T} \times 100 (\%)$$

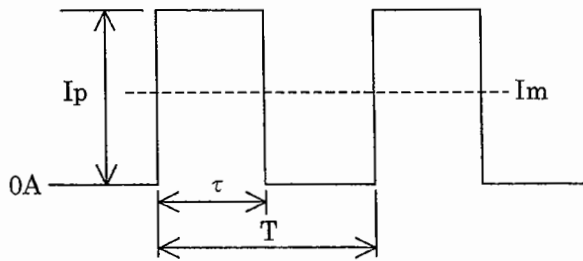

- I_p : Peak output current (A)
- I_{av} : Rated output current (A)
- I_m : Average output current (A)
- τ : Peak current pulse width (sec)
- T : cycle (sec)

4. Mounting Directions

4-1. Output Derating

Mounting directions are as follows.
Standard mounting method is (A). Methods (B), (C) and (D) are also possible.
Mounting methods besides (A),(B),(C) and (D) (example : (E) and (F)) are inhibit.

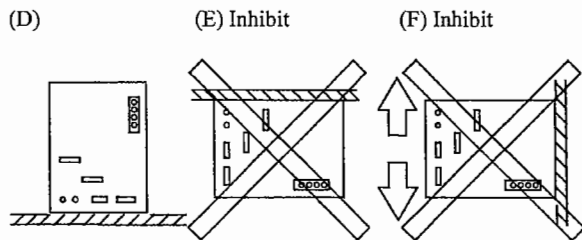
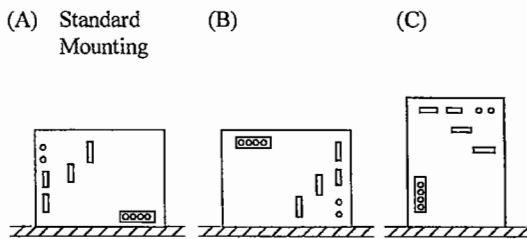

HWS1500 Output Derating

Ta(°C)	LOAD(%)			
	A	B	C	D
-10 ~ +35	100	100	100	100
45	100	100	100	100
50	100	100	100	100
60	75	75	75	75
70	50	50	50	50

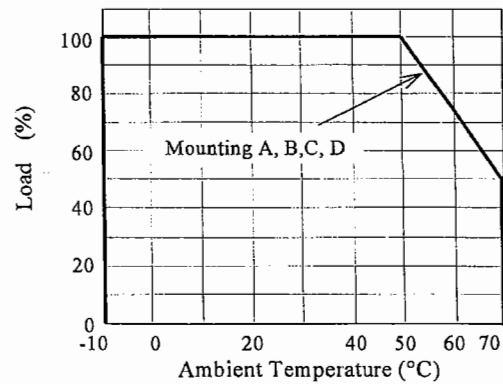

4-2. Mounting Method Caution

- (1) This Power supply unit is a forced air-cooling system with a built-in fan.
- (2) This power supply has ventilating holes on the front and back panels.
Keep these areas freely more than 100mm from front side and more than 50mm from rear side.
- (3) Please note that ventilation will be worsened in a dusty environment.
- (4) Built-in fan is limited life part, which require periodic replacement. (Replacement will be charge).
- (5) The ambient temperature of this power supply is less than 50mm from the center of a front side.
- (6) The maximum allowable penetration of mounting screw is 6mm.
- (7) Recommended torque for mounting screw (M4) is 1.27N · m.

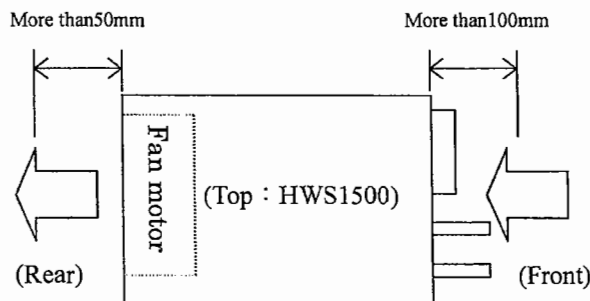

5. Wiring Method

- (1) The output load line and input line shall be separated and twisted to improve noise sensitivity.
- (2) The sensing lines shall be twisted or shield wire and separated from the output lines.
- (3) Use all lines as thick and short as possible to make lower impedance. Wires are to be twisted or use shield wire to improve noise sensitivity.
- (4) Attaching a capacitor to the load terminals can eliminate noise.
- (5) FG terminal of this power supply is functional earthing. For safety purposes, connect protective earthing terminal to the mounting set ground terminal.
- (6) Recommended torque for the terminal piece:

Input terminal (M4 screw) : 1.27 N·m Output terminal (M8 Bolt & Nut) : 10.8N·m

(7) Recommended wiring

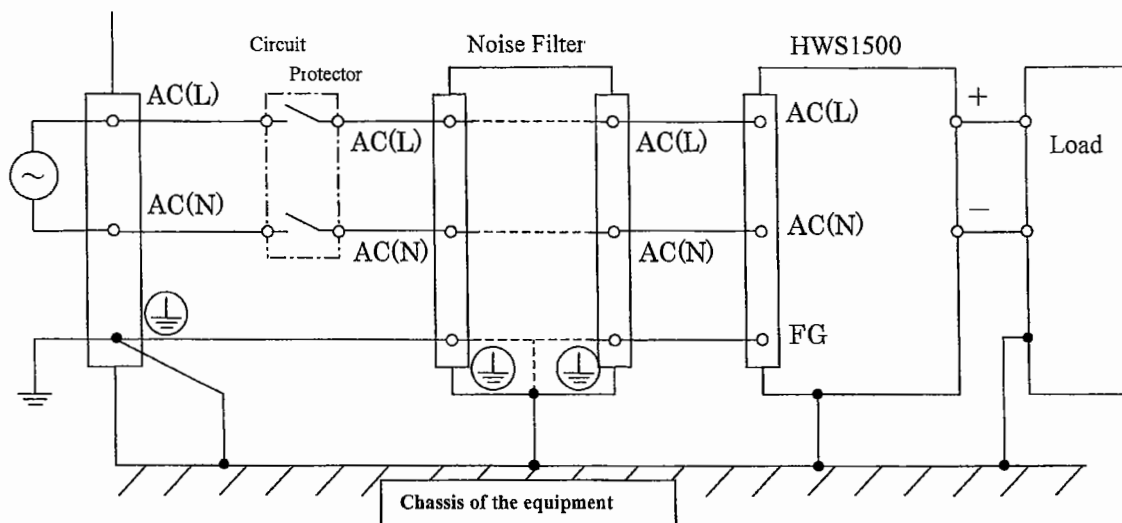

Recommended circuit protector : AC250V30A
 Recommended noise filter : MXB1220 (DENSEI-LAMBDA)

6. External Fuse Rating

Refer to the following fuse rating when selecting the external fuses for input line. Surge current flows when line turns on. Use slow-blow fuse or time-lag fuse. Do not use fast-blow fuse. Fuse rating is specified by in-rush current value at line turn-on. Do not select the fuse according to input current (rms.) values under the actual load condition.

- HWS1500:30A

7. Troubleshooting

Before concluding that the unit is at fault, make the following checks.

- (1) Check if the rated input voltage is apply.
- (2) Check if the wiring of input and output is correct.
- (3) Check if the I/O terminal connection is properly tighten by a regulated tightening torque.
- (4) Check if the wire material is not too thin.
- (5) Check if the output voltage control (V.ADJ) is properly adjusted. OVP might be trigged and output is cut off.
- (6) Check if the wiring of "+S" and "-S" terminal is correct. If in open condition, when input voltage is apply, OVP is trigged and output is cut off. Output display LED will turn on for a moment.
- (7) If use function of the remote ON/OFF control, check if the remote ON/OFF control connector is not opened.
If in open condition, output is cut off.
- (8) Check if the built-in fan is not stopped. Is fan stopped by something irregulars or dust, etc.
If fan stops, the PF signal is turn on.
Moreover, the output is intercepted with the protection circuit if fan stops.
Fans are the limited life parts.
This power supply has ventilating holes on the front and back panels. Check if there is any irregulars or dust, etc.
- (9) Is the main body of the power supply abnormally hot?
Please turn on the input again after allowing the unit to cool down sufficiently. The output shut down by over temperature protection function.
- (10) Check if the output current and output power is not applied over specification.
- (11) Check if the input voltage wave is sinusoidal. If this power supply unit is connected to a UPS, input voltage wave might not be sinusoidal. An audible noise is emmitted from the power supply unit.
- (12) Audible noise can be heard during Dynamic-Load operation.

8. Warranty

This product is warranted for a period of 5 years from the date of shipment. As for the breakdown under a normal use during free warrantee term, repair is at free of charge. However, the Built-in Fan Motor replacement is for a fee. Please contact your nearest sales office for replacement.

The Fan-life has limitation. Therefore, periodic maintenance by replacing the life-expired fan is required. The following figure shows the life of fan.

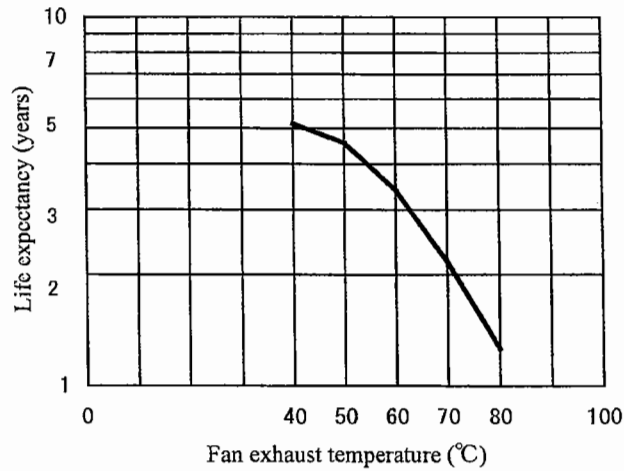

Life expectancy	Fan exhaust temperature	45°C	45,000	hour
	Fan exhaust temperature	80°C	11,000	hour

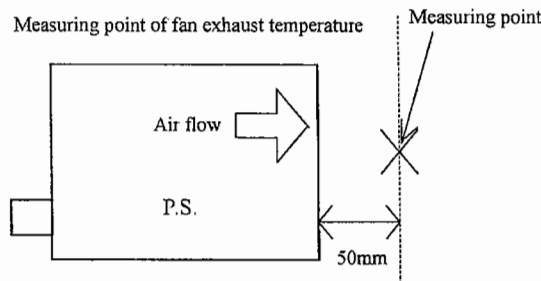

Conditions of usage at the free of charge warrantee are as follows.

- (1) Average operating temperature (ambient temperature of the power supply unit) is 40°C
- (2) Average load factor is 80% or less
- (3) Installation method: Standard installation. However, the maximum rating is within the output derating.

Following cases are not covered by warranty.

- (1) Improper usage like dropping products, applying shock and defects from operation exceeding specification of the units.
- (2) Defects resulting from natural disaster (fire, flood).
- (3) Unauthorized modifications or repair by the buyers.
- (4) Defects not cause by DENSEI LAMBDA.