

FEC15W SERIES

DC / DC Single & Dual Output: 15 Watts



Features

- 4:1 wide Input range option 9~36V & 18~75V
- Single & Dual outputs
- Industry Standard 2 x 1in package
- High efficiency up to 83%
- Regulated output & Short circuit protection
- 1600V isolation
- Five sided continuous copper shield
- Remote ON / OFF (Negative or Positive) - option
- High operating temperature +85°C
- Zero load operation
- Safety EN60950, UL1950
- EMC Compliant

Specifications:

Input Voltage	24VDC (9 ~ 36) 48VDC (18 ~ 75)
Input Filter	Pi type
Input Surge Voltage. (100mS)	24V: 50VDC. 48V: 100VDC
Input Reflected Ripple Current	20mA pk-pk (@ nominal input & 100% load
Start Up time	20mS constant resistive load
Remote ON/OFF (Positive logic) (Negative logic) (Option)	DC-DC ON Open or 3.0V < Vr < 12V DC-DC OFF Short or 0V < Vr < 1.2V DC-DC ON Short or 0V < Vr < 1.2V DC-DC OFF Open or 3.0V < Vr < 12V Input current of remote control pin: 0.5mA Remote off state input current: 2.5mA
Output power	15 watts
Voltage Accuracy	±1.0%
Minim Load	Zero
Line Regulation	Single ±0.2% Dual ±0.5%
Load Regulation	Single ±0.5% , Dual ±1% (0% -100% load)
Cross Regulation	±5% Asymmetrical load: 25-100% load)
Ripple & noise	See table. 20MHZ bandwidth
Temp. Coefficient	±0.02% / °C
Transient Response	250uS (25% load step change)
Over Voltage Protection	3.3V: 3.9V 5.0V: 6.2V 12V: 15V 15V: 18V
Overload Protection	Typically 150% of load
Short Circuit protection	Continuous hiccup mode

Efficiency	Model dependant 86 ~ 88%
Isolation	1600VDC
Isolation Cap.	1500pF
Case Grounding	Connect case to -Vin with decoupling Y cap.
Switching Freq.	Standard 400KHz
Safety	EN60950-1, UL60950-1
Case Material	Nickel-coated copper
Base Material	Non-conductive black plastic
Potting	Epoxy UL94-V0
Dimensions	50.8 x 25.4 x 10.2mm
Weight	27g
MTBF	1.697 x 10 ⁶ Hrs
Operating Temp	-40°C to +76°C (without derating) -40°C to +100°C (with derating)
Case Temp	+100°C maximum case temperature
Thermal Impedance	12°C / watt Standard convection 10°C / watt with optional heatsink
Thermal shock	MIL-STD-810F
Vibration	10-55Hz, 10G, 30min along X, Y,Z
Humidity	5-95% RH
EMC	EN55022 Class A Consult office for Class B design
ESD	EN61000-4-2
Radiated Immunity	EN61000-4-3
Fast Transients	EN61000-4-4
Surge	EN61000-4-5
Conducted Immunity	EN61000-4-6

FEC15W SERIES

DC / DC Single & Dual Output: 15 Watts

Model	Input V	Output V	Output Current		Output Ripple & Noise	Input Current		Eff (%)	Capacitor Load max
			Min. load	Full load		No Load	Full Load		
FEC15-24S3P3W	9 – 36 V	3.3 V	0mA	4500mA	50mVp-p	50mA	755mA	86	14700uF
FEC15-24S05W	9 – 36 V	5 V	0mA	3000mA	50mVp-p	65mA	753mA	87	7200uF
FEC15-24S5P1W	9 – 36 V	5.1 V	0mA	3000mA	50mVp-p	65mA	768mA	87	7200uF
FEC15-24S12W	9 – 36 V	12 V	0mA	1250mA	75mVp-p	22mA	753mA	87	1250uF
FEC15-24S15W	9 – 36 V	15 V	0mA	1000mA	75mVp-p	22mA	753mA	87	800uF
FEC15-24D05W	9 – 36 V	± 5 V	0mA	± 1500mA	75mVp-p	55mA	753mA	87	± 3600uF
FEC15-24D12W	9 – 36 V	± 12 V	0mA	± 625mA	75mVp-p	30mA	744mA	88	± 625uF
FEC15-24D15W	9 – 36 V	± 15 V	0mA	± 500mA	75mVp-p	30mA	744mA	88	± 400uF
FEC15-48S3P3W	18 – 75 V	3.3 V	0mA	4500mA	50mVp-p	35mA	377mA	86	14700uF
FEC15-48S05W	18 – 75 V	5 V	0mA	3000mA	50mVp-p	35mA	372mA	88	7200uF
FEC15-48S5P1W	18 – 75 V	5.1 V	0mA	3000mA	50mVp-p	35mA	379mA	88	7200uF
FEC15-48S12W	18 – 75 V	12 V	0mA	1250mA	75mVp-p	15mA	377mA	87	1250uF
FEC15-48S15W	18 – 75 V	15 V	0mA	1000mA	75mVp-p	15mA	377mA	87	800uF
FEC15-48D05W	18 – 75 V	± 5 V	0mA	± 1500mA	75mVp-p	35mA	372mA	88	± 3600uF
FEC15-48D12W	18 – 75 V	± 12 V	0mA	± 625mA	75mVp-p	17mA	372mA	88	± 625uF
FEC15-48D15W	18 – 75 V	± 15 V	0mA	± 500mA	75mVp-p	17mA	372mA	88	± 400uF

Notes:

1. MTBF as per BELLCORE TR-NWT-000332. Case 1: 50% Stress, Temperature at 40°C. (Ground fixed and controlled environment)
MIL-STD-217F Notice2 @Ta=25 °C, Full load(Ground, Benign, controlled environment)
2. Typical values at nominal input voltage and full resistive load.
3. The ON/OFF control pin voltage is referenced to -Vin.
To order positive logic ON/OFF control add the suffix **-P** (eg: FEC15-48S05W-P) Negative logic ON/OFF control add the suffix **-N** (eg: FEC15-48S05W-N)
4. Heat sink is optional and **P/N: 7G-0020A**
5. The FEC15W series can meet EN55022 Class A with parallel an external capacitor to the input pins.
Recommend : 24Vin : NA. 48Vin : 1µF/100V 1210 MLCC.
6. An external filter capacitor is required if the module has to meet EN61000-4-5. Recommend Nippon chemi-con KY series, 220µF/100V, ESR 48mΩ.

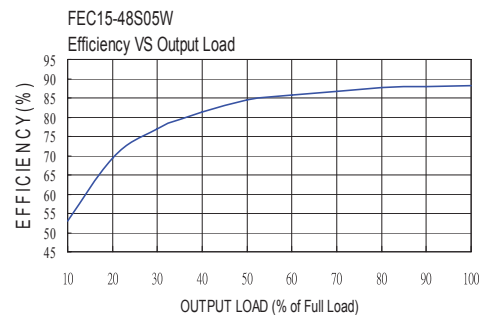
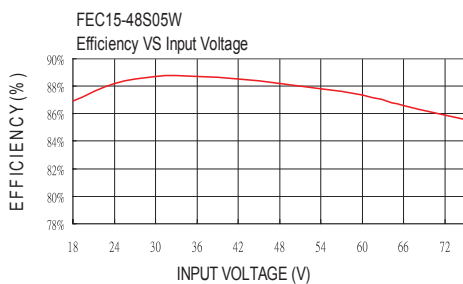
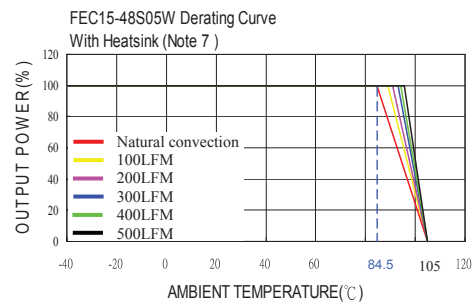
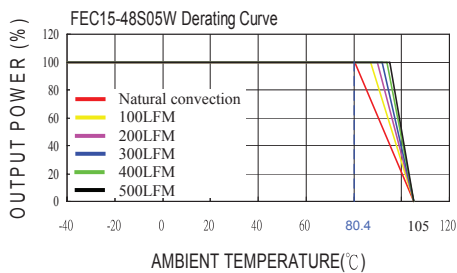

FEC15W SERIES

DC / DC Single & Dual Output: 15 Watts

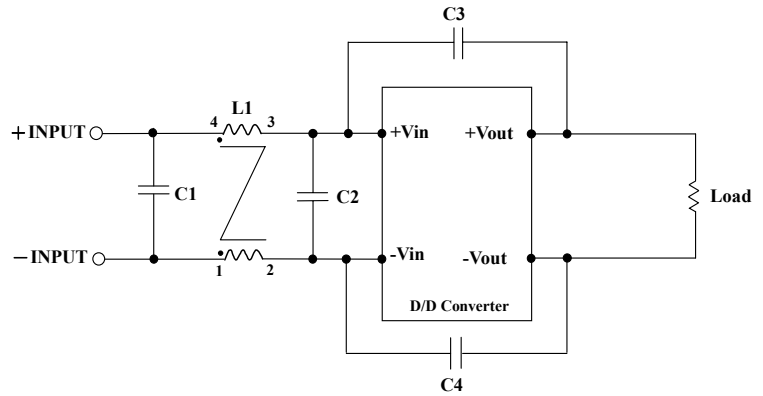

Recommended Filter for EN55022 Class B Compliance

The components used in the above figure, together with the manufacturers' part numbers for these components, are as follows:

	C1	C2	C3	C4	L1
FEC15-24XXXW	2.2uF/50V 1812 MLCC	N/A	1000pF/2KV MLCC	1000pF/2KV MLCC	450uH Common Choke PMT-048
FEC15-48XXXW	2.2uF/100V 1812 MLCC	2.2uF/100V 1812 MLCC	1000pF/2KV MLCC	1000pF/2KV MLCC	325uH Common Choke PMT-050

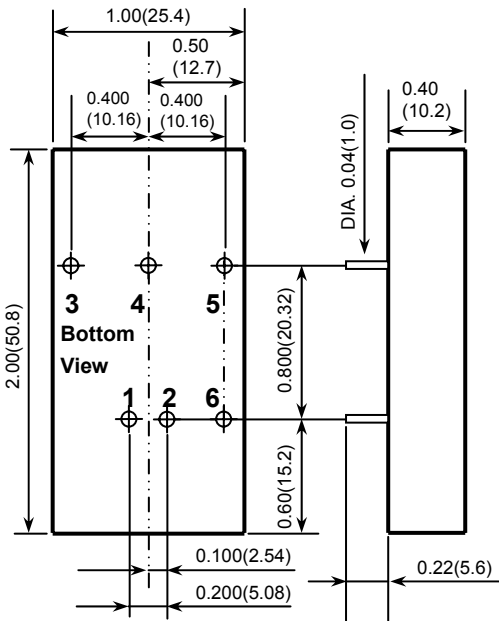

- All dimensions in Inches (mm)
Tolerance: X.XX±0.02 (X.X±0.5)
X.XXX±0.01 (X.XX±0.25)
- Pin pitch tolerance ±0.01(0.25)
- Pin dimension tolerance ±0.004 (0.1)

Pin Assignment		
PIN	Single	Dual
1	+ Input	+ Input
2	- Input	- Input
3	+ Output	+ Output
4	NO PIN	COMMON
5	- Output	- Output
6	CTRL (Option)	CTRL (Option)

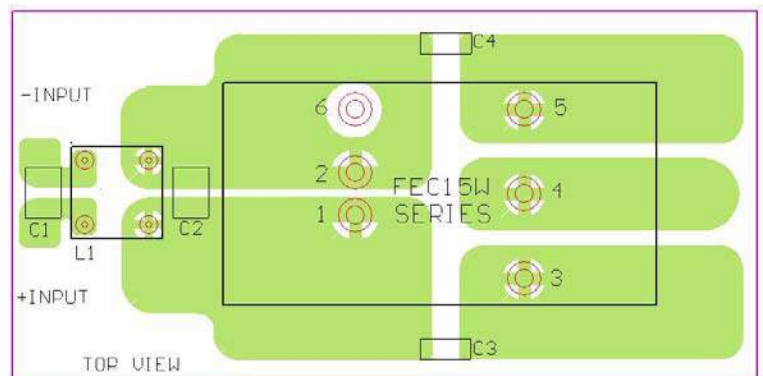

Recommended EN55022 Class B Filter Circuit Layout