

BCH1K5F / BCH2KF SERIES

Battery Chargers: 1000 ~ 2000 Watts



Specifications

Input Voltage	230VAC (190 ~ 264)
Input Frequency	47 ~ 63Hz
Input Current	9.5A 1kw, 14A 1.5kw, 19A 2kw
Input Protection	Inrush current limiting Transient protection / Varistors Internal safety fuse
Isolation	Input – Output: 4300vdc Input - Chassis 2250vdc Output – Chassis 500vdc
Efficiency	Typically 80%
Output voltage	See table
Output Power	1000 ~ 2000 watts
Voltage adjustment	24V: 24-28V 48V 48-56V 96V: 108-127V 108V: 108-127V
EMC	EN55022 Class A
Immunity	EN 61000-4-2 (ESD) EN 61000-4-3 (RF Immunity) EN 61000-4-4 (Fast Transients) EN 61000-4-6 (Conducted Imm.)
Switching Freq.	Typically 55KHz
Output Diode	Internally fitted output isolation diode
Parallel operation	Yes
Regulation	Line: $\pm 1\%$ Load: $\pm 1.5\%$
Output Ripple/Noise	Typically <1% of output voltage
Overload Protection	Constant current limiting with short circuit protection. Battery must be externally fused.
Thermal Protection	Thermal shutdown with auto recovery, when unit cools down.
Overvoltage Protection	Yes. Recycle mains input to re-set
Operating Temp.	0°C to +50°C at full load. Derate 2.5% per °C to +70°C.
Temperature Drift	0.03% per °C over operating range

Features

- Three power levels: 1KW, 1.5KW & 2KW
- Industrial grade product
- Fully isolated input – output
- Over voltage protection
- Overload and short circuit protection
- Inrush current limiting
- MTBF > 150,000hrs
- Any output from 24vdc ~ 120vdc possible
- Customised mechanical solutions on request
- Power Fail / Charger Fail Alarm
- Battery Low Alarm

Description

The BCH1K ~ 2K series battery charger is a rugged, industrial-grade product, using field-proven design suitable for use in DC battery back-up applications.

It is a mature product providing excellent reliability and performance and delivering up to 2000 watts of output power.

The two alarms provide external monitoring of Power Fail / Charger Fail and Battery Low via voltage free contacts. The chassis-mount design feature allows for easy mounting.

Additional ruggedizing and conformal coating are available for applications requiring higher immunity to shock, vibration, humidity, moisture, dust and insects .

Options

TBC	Temperature Battery Compensation Charging
TIM	Automatic Battery Testing
Boost	A variety of boost options

Specifications Cont.

Cooling	Fan cooled
Shock & Vibration	IEC61373 Cat 1 A&B
Humidity	5-95% non-condensing
MTBF	>150,000hrs @ 45°C
Indicator	Green LED visible through cooling slots
Alarm Output	<ul style="list-style-type: none">• Power Fail / Charger Fail Alarm• Low Battery Alarm Both Alarms are CLOSE FAIL with common return Low battery only operative if power / charger fails.
Connections	Terminal block / barrier strip with 3/8" spacing
Dimensions	349 x 237 x 66mm (FF6)
Weight	3.6kg

BCH1K5F / BCH2KF SERIES

Battery Chargers: 1000 ~ 2000 Watts

Model	Output			Power W
	Nom V	Float V	A	
BCH1KF-28FT	24V	27.6V	36A	1000W
BCH1KF-55FT	48V	55.2V	18A	1000W
BCH1K5F-28FT	24V	27.6V	50A	1400W
BCH1K5F-55FT	48V	55.2V	27A	1500W
BCH1K5F-110FT	96V	108.0V	12A	1500W
BCH1K5F-110FT	108V	124.0V	12A	1500W

110V model adjustable for use on 96V or 108V nominal battery systems

Model	Output			Power W
	Nom V	Float V	A	
BCH2KF-28FT	24V	27.6V	70A	2000W
BCH2KF-55FT	48V	55.2V	36A	2000W
BCH2KF-110FT	96V	108.0V	16A	2000W
BCH2KF-110FT	108V	124.0V	16A	2000W

110V model adjustable for use on 96V or 108V nominal battery systems

BCH1KW ~ BCH2KW

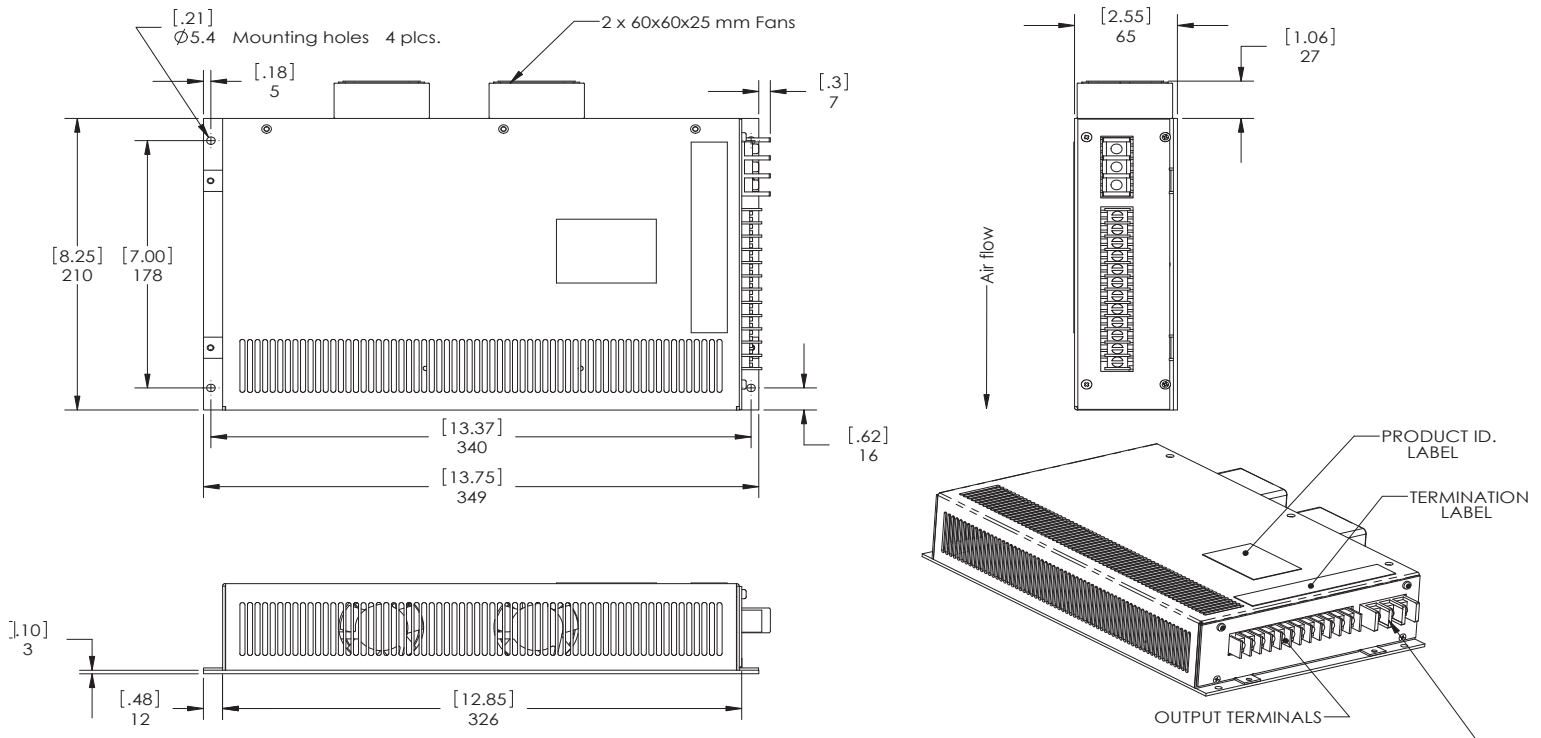

DC OUTPUT					ALARMS			230VAC INPUT						
+	+	+	+ LED	-	-	-	COM	LBA	CFA	GND	N	PH		
1	2	3	4	5	6	7	8	9	10	11	12	1	2	3