

400-2500 Watts

flex Power Series



- Configurable for Fast Time to Market
- SEMI F47 Compliant
- Flexible Series & Parallel Capability
- -20 °C Operation
- Extra Power Available at High Line
- Optional Fan Speed Control
- 3 Year Warranty

Specification

Input

Input Voltage	• 85-264 VAC (120-370VDC). Full power at 90 VAC, derate by 10% at 85 VAC. 3 phase input is available, see 3 phase flexPower datasheet.
Input Frequency	• 47-63 Hz, 400 Hz (all specifications met at 400 Hz, except leakage current)
Input Current ⁽¹⁾	• X4: 5.33 A at 115 VAC, 2.67 A at 230 VAC X5: 6.67 A at 115 VAC, 3.33 A at 230 VAC X7: 9.33 A at 115 VAC, 4.67 A at 230 VAC X9: 12.0 A at 115 VAC, 6.00 A at 230 VAC X10: 13.3 A at 115 VAC, 6.67 A at 230 VAC X15: 20 A at 115 VAC, 10 A at 230 VAC
Inrush Current ⁽¹⁾	• X4, X5, X7: <20 A, X9/X10: <40 A, X15: <60 A, cold start at 25 °C
Power Factor	• 0.99 typical at 115 VAC & 230 VAC full load
Earth Leakage Current ⁽¹⁾	• X models: <1.5 mA at 264 VAC, 50 Hz XM7-10: <200 µA at 264 VAC, 50 Hz XM15: <300 µA at 115 VAC 60 Hz, <400 µA at 264 VAC 50 Hz
Input Protection	• X4-7/XM4-7: T12 A/250 V, X9/XM9: T15 A/250 V, X10/XM10: T20 A/250 V, X15/XM15: T30 A/250 V, internal fuse in line and neutral

Output

Output Power	• See table
Output Voltage	• See table
Output Voltage Trim	• 3.3 V outputs ±6%, others ±10%
Minimum Load	• No min load required for 2 slot, 3 slot or 4 slot single output modules on 6x dual output models. 5x dual outputs require 10% load on V1 to meet specified regulation on V2
Start Up Delay	• 2 s typical
Hold Up Time	• 20 ms at 90 VAC input & full output load
Line Regulation	• <0.1%
Load Regulation	• <1.0%
Ripple & Noise	• 50 mV or 1% pk-pk at 20 MHz bandwidth, whichever is greater. 6E module has 1.5% on V1 and V2. 6N module has 1.5% on V1 and 3% on V2
Overvoltage Protection	• 115-130% Vnom, 115-140% Vnom for 6E and 6N modules
Overtemperature Protection	• 115 °C measured internally, auto resetting
Overload Protection	• 110-140% for 2x, 3x and 4x modules 110-150% for 1x modules 110-150% on V1 and 110-200% on V2 of 5x modules 110-200% on V1 and V2 of 6x modules
Short Circuit Protection	• Continuous trip & restart (hiccup mode)
Temperature Coefficient	• 0.03%/°C
Remote Sense	• Compensates for up to 0.5 V drop
Enable/Inhibit	• See signals page
Current Share	• See signals page
Housekeeping Voltage	• 5 V/1 A from each chassis

General

Efficiency	• Up to 89%
Isolation	• 4000 VAC Input to Output 2 x MOPP, 1500 VAC Input to Ground 1 x MOPP, 250 VDC Output to Ground
Switching Frequency	• 60 kHz typ PFC, 200 kHz typ modules
Signals	• See signals page
MTBF	• 225 kHrs typ to MIL-HDBK-217F at 25 °C, GB

Environmental

Operating Temperature	• -20 °C to +70 °C. For operation above +50 °C, derate linearly to 50% load at +70 °C. Reverse air option derate from +40 °C to half load at +60 °C
Cooling	• Forced air cooling (via field-replaceable internal fan). Fan speed control optional
Operating Humidity	• 5-95% RH, non-condensing
Storage Temperature	• -40 °C to +85 °C
Operating Altitude	• 3000 m at full specification
Shock	• MIL STD-810 Method 516.4 Procedure 1, 30 g, half sine, 6 axes
Vibration	• MIL STD-810 Method 514.4 Procedure 1, 1 g rms, 5-500 Hz, 3 axes

EMC & Safety

Emissions	• X version: EN55022 (CISPR 22) Class B conducted XM version: EN55011 (CISPR 11) Class A conducted
Immunity	• EN60601-1-2, EN61204-3
Harmonic Currents	• EN61000-3-2, Class A
Voltage Flicker	• EN61000-3-3
ESD Immunity	• EN61000-4-2, level 4 Perf Criteria A
Radiated Immunity	• EN61000-4-3, 10 V/m Perf Criteria A
EFT/Burst	• EN61000-4-4, level 3 Perf Criteria A
Surge	• EN61000-4-5, installation class 3, Perf Criteria A, SEMI F47
Conducted Immunity	• EN61000-4-6, level 3 Perf Criteria A
Dips and Interruptions	• EN61000-4-11, 30% 10 ms, 60% 100 ms, 100% 5000 ms, Perf Criteria A, B, EN60601-1, 30% 500 ms, 60% 100 ms, 100% 10 ms, 100% 5000 ms, Perf Criteria A, A (with 60% load), A, B
Safety Approvals	• EN60601-1, ANSI/AAMI ES60601-1, CSA22.2 No.60601-1 per cUL, Including Risk Management XM Models, EN60950, UL60950 X Models

Notes

1. Current specifications double for DD chassis versions.
(Low leakage for EN60601-1-2 available as modified standard, contact sales)

Configuration – Model Number Construction

flexPower

AC-DC

The flexPower range allows for simple configuration of a custom modular power supply with up to twenty outputs. The chassis consists of either ten, twelve, fourteen or twenty slots, and modules are either two, three or four slots wide. Please refer to next page for specific X15 configuration information.

CHASSIS

OUTPUT MODULES 1-5 (1-6: 900 W chassis/ 1-7: 1000 W chassis)

OPTIONS

X	X	X	X
---	---	---	---

--	--	--	--	--	--	--	--	--	--	--	--	--

P	P	S	S	+	+
---	---	---	---	---	---

Model	Sector	Vinput				Slots
		115 V		230 V		
		Pnom	Ppk*	Pnom	Ppk*	
X4	Industrial	400 W	800 W	600 W	1200 W	10
XM4	Medical	400 W	800 W	600 W	1200 W	10
X5	Industrial	500 W	800 W	700 W	1200 W	10
XM5	Medical	500 W	800 W	700 W	1200 W	10
X7	Industrial	700 W	800 W	900 W	1200 W	10
XM7	Medical	700 W	800 W	900 W	1200 W	10
X9	Industrial	900 W	1100 W	1100 W	1500 W	12
XM9	Medical	900 W	1100 W	1100 W	1500 W	12
X10	Industrial	1000 W	1300 W	1200 W	1600 W	14
XM10	Medical	1000 W	1300 W	1200 W	1600 W	14

Single Output - Module Voltage/Current Rating						
Voltage	Current	Ipk	Power	Ppk	Slots	Code
3.3 V	20.0 A	n/a	66 W	n/a	2	1C
3.3 V	40.0 A	n/a	132 W	n/a	2	2C
3.3 V	60.0 A	n/a	198 W	n/a	3	3C
5.0 V	20.0 A	n/a	100 W	n/a	2	1D
5.0 V	40.0 A	n/a	200 W	n/a	2	2D
5.0 V	60.0 A	n/a	300 W	n/a	3	3D
8.0 V	25.0 A	n/a	200 W	n/a	2	2H
10.0 V	20.0 A	n/a	200 W	n/a	2	2I
10.0 V	30.0 A	n/a	300 W	n/a	3	3I
12.0 V	8.50 A	n/a	102 W	n/a	2	1J
12.0 V	17.0 A	n/a	204 W	n/a	2	2J
12.0 V	25.0 A	n/a	300 W	n/a	3	3J
12.0 V	62.5 A	n/a	750 W	n/a	4	4J
15.0 V	7.00 A	n/a	105 W	n/a	2	1L
15.0 V	14.0 A	n/a	210 W	n/a	2	2L
15.0 V	20.0 A	n/a	300 W	n/a	3	3L
15.0 V	50.0 A	n/a	750 W	n/a	4	4L
18.0 V	16.7 A	n/a	300 W	n/a	3	3N
24.0 V	5.00 A	n/a	120 W	n/a	2	1P
24.0 V	10.5 A	n/a	252 W	n/a	2	2P
24.0 V	17.0 A	n/a	408 W	n/a	3	3P
24.0 V	31.5 A	n/a	750 W	n/a	4	4P
24.0 V	5.00 A	10.0 A	120 W	240 W	2	1R ⁽¹⁾
24.0 V	10.5 A	21.0 A	252 W	504 W	2	2R ⁽¹⁾
24.0 V	17.0 A	34.0 A	408 W	816 W	3	3R ⁽¹⁾
28.0 V	4.50 A	n/a	126 W	n/a	2	1Q
28.0 V	9.00 A	n/a	252 W	n/a	2	2Q
28.0 V	14.0 A	n/a	392 W	n/a	3	3Q
28.0 V	26.8 A	n/a	750 W	n/a	4	4Q
30.0 V	8.4 A	n/a	252 W	n/a	2	2S
30.0 V	13.5 A	n/a	405 W	n/a	3	3S
36.0 V	3.50 A	n/a	126 W	n/a	2	1U
36.0 V	7.00 A	n/a	252 W	n/a	2	2U
36.0 V	11.0 A	n/a	396 W	n/a	3	3U
36.0 V	21.0 A	n/a	750 W	n/a	4	4U
42.0 V	9.05 A	n/a	400 W	n/a	3	3V
48.0 V	2.50 A	n/a	120 W	n/a	2	1W
48.0 V	5.20 A	n/a	249 W	n/a	2	2W
48.0 V	8.50 A	n/a	408 W	n/a	3	3W
48.0 V	15.7 A	n/a	750 W	n/a	4	4W
60.0 V	2.00 A	n/a	120 W	n/a	2	1Y
60.0 V	4.20 A	n/a	252 W	n/a	2	2Y
60.0 V	7.00 A	n/a	420 W	n/a	3	3Y
60.0 V	12.5 A	n/a	750 W	n/a	4	4Y

Parallel Option Codes	
Code	Description
00	No parallel required
12	Modules 1 & 2
13	Modules 1 to 3
14	Modules 1 to 4
23	Modules 2 & 3
24	Modules 2 to 4
25	Modules 2 to 5
34	Modules 3 & 4
35	Modules 3 to 5
40	Modules 1 & 2, 3 & 4

Series Option Codes	
Code	Description
00	No series required
12	Modules 1 & 2
13	Modules 1 to 3
23	Modules 2 & 3
24	Modules 2 to 4
40	Modules 1 & 2, 3 & 4

Other Option Codes	
Code	Description
01	Reverse Air
02	Global Enable - Logic 1
03	Option 01 & 02
04	Global DC OK - Logic 1
05	Option 01 & 04
06	Option 02 & 04
07	Option 01, 02 & 04
08	Global AC OK - Logic 1
09	Option 01 & 08
10	Option 02 & 08
11	Option 01, 02 & 08
12	Option 04 & 08
13	Option 01, 04 & 08
14	Option 02, 04 & 08
15	Option 01, 02, 04 & 08
16	Fan Speed Control
17	Option 01 & 16
18	Option 02 & 16
19	Option 04 & 16
20	Option 08 & 16
21	Option 01, 02 & 16
22	Option 01, 04 & 16
23	Option 01, 08 & 16
24	Option 02, 04 & 16
25	Option 02, 08 & 16
26	Option 04, 08 & 16
27	Option 01, 02, 04 & 16
28	Option 01, 02, 08 & 16
29	Option 02, 04, 08 & 16
30	Option 01, 02, 04, 08 & 16

Note: Peak power available for 10 seconds with 35% duty cycle.

Step 1

To configure your flexPower unit, select the required output power and application type. flexPower chassis are available in multiple power formats.

Step 2

flexPower can accommodate up to ten modules, resulting in an extensive range of output combinations. However, as all modules are designed to fit across either 2, 3 or 4 slots in the chassis, configuration is very simple. Select the appropriate modules for your output requirements, ensuring that all modules will fit in the chassis. First, insert 4 series modules, ordered lowest voltage to highest. Next in order, insert 3 series modules, ordered lowest voltage highest. Follow with 2 series, then 5 series dual output, ordered alphabetically a-z. Then 1 series, ordered lowest voltage to highest.

Step 3

Add any required options. These are grouped into three types; parallel options, series options and other options. The standard signal set for each chassis includes Global Inhibit, Global DC OK and Global AC OK, each having logic 0 operation. Optionally a logic 1 operating version of each is available along with reverse air flow. Also available is a fan speed control option, which is available separately or combined with previously listed options.

Dual Output - Module Voltage/Current Rating					
Output 1		Output 2		Slots	Code
Voltage	Current	Voltage	Current		
5.0 V	10.0 A	5.0 V	10.0 A	2	5A
5.0 V	10.0 A	3.3 V	10.0 A	2	5B
12.0 V	10.0 A	12.0 V	8.0 A	2	5D
15.0 V	8.0 A	15.0 V	6.0 A	2	5E
15.0 V	8.0 A	15.0 V	6.0 A	2	6E*
15.0 V	8.0 A	12.0 V	8.0 A	2	5F
12.0 V	10.0 A	5.0 V	10.0 A	2	5G
12.0 V	10.0 A	3.3 V	10.0 A	2	5H
12.0 V	10.0 A	2.0 V	10.0 A	2	5J
15.0 V	10.0 A	5.0 V	10.0 A	2	5K
15.0 V	10.0 A	3.3 V	10.0 A	2	5L
15.0 V	10.0 A	2.0 V	10.0 A	2	5M
24.0 V	6.0 A	5.0 V	10.0 A	2	5N
24.0 V	6.0 A	5.0 V	10.0 A	2	6N*
24.0 V	6.0 A	3.3 V	10.0 A	2	5P
24.0 V	6.0 A	2.0 V	10.0 A	2	5Q

Note: Total power for dual output module must not exceed 175 W max. 6x modules do not need minimum load on output 1 for regulation

1. Peak power available for 10 seconds with 35% duty cycle, if peak power rating is exceeded output may latch, recycle input to reset.

Example

X7-3C3L2C-000016

X7 - 700 W industrial chassis, 10 module slots available.
3C - 3.3 V @ 60.0 A. Three slot width module.

3L - 15.0 V @ 20.0 A. Three slot width module.

2C - 3.3 V @ 40.0 A. Two slot width module.

00 - No parallel option.

00 - No series option.

16 - Fan speed control card.

Note:

1. Fancard options 16-30 will occupy 2 slots. See mechanical drawing.

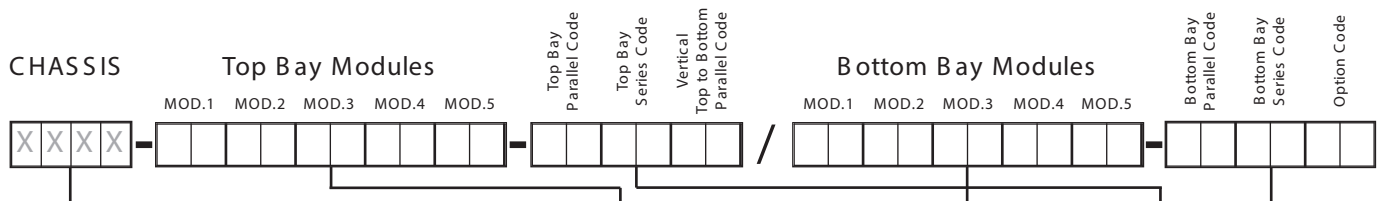

Model	Sector	Vinput		Slots
		115 V	230 V	
		Max Power	Max Power	
X15	Industrial	1500 W	2500 W	20
XM15	Medical	1500 W	2500 W	20

Step 1

To configure your fleXPower unit, select the required output power and application type. fleXPower chassis are available in multiple power formats.

Step 2

fleXPower can accommodate up to ten modules, resulting in an extensive range of output combinations. However, as all modules are designed to fit across either 2, 3 or 4 slots in the chassis, configuration is very simple. Select the appropriate modules for your output requirements, ensuring that all modules will fit in the chassis. First, insert 4 series modules, ordered lowest voltage to highest. Next in order, insert 3 series modules, ordered lowest voltage highest. Follow with 2 series, then 5 series dual output, ordered alphabetically a-z. Then 1 series, ordered lowest voltage to highest.

Step 3

Add any required options. These are grouped into three types; parallel options, series options and other options. The standard signal set for each chassis includes Global Inhibit, Global DC OK and Global AC OK, each having logic 0 operation. Optionally a logic 1 operating version of each is available along with reverse air flow. Also available is a fan speed control option, which is available separately or combined with previously listed options.

Dual Output - Module Voltage/Current Rating					
Output 1		Output 2		Slots	Code
Voltage	Current	Voltage	Current		
5.0 V	10.0 A	5.0 V	10.0 A	2	5A
5.0 V	10.0 A	3.3 V	10.0 A	2	5B
12.0 V	10.0 A	12.0 V	8.0 A	2	5D
15.0 V	8.0 A	15.0 V	6.0 A	2	5E
15.0 V	8.0 A	15.0 V	6.0 A	2	6E*
15.0 V	8.0 A	12.0 V	8.0 A	2	5F
12.0 V	10.0 A	5.0 V	10.0 A	2	5G
12.0 V	10.0 A	3.3 V	10.0 A	2	5H
12.0 V	10.0 A	2.0 V	10.0 A	2	5J
15.0 V	10.0 A	5.0 V	10.0 A	2	5K
15.0 V	10.0 A	3.3 V	10.0 A	2	5L
15.0 V	10.0 A	2.0 V	10.0 A	2	5M
24.0 V	6.0 A	5.0 V	10.0 A	2	5N
24.0 V	6.0 A	5.0 V	10.0 A	2	6N*
24.0 V	6.0 A	3.3 V	10.0 A	2	5P
24.0 V	6.0 A	2.0 V	10.0 A	2	5Q

Note: Total power for dual output module must not exceed 175 W max. 6x modules do not need minimum load on output 1 for regulation

Single Output - Module Voltage/Current Rating						
Voltage	Current	Ipk	Power	Ppk	Slots	Code
3.3 V	20.0 A	n/a	66 W	n/a	2	1C
3.3 V	40.0 A	n/a	132 W	n/a	2	2C
3.3 V	60.0 A	n/a	198 W	n/a	3	3C
5.0 V	20.0 A	n/a	100 W	n/a	2	1D
5.0 V	40.0 A	n/a	200 W	n/a	2	2D
5.0 V	60.0 A	n/a	300 W	n/a	3	3D
8.0 V	25.0 A	n/a	200 W	n/a	2	2H
10.0 V	20.0 A	n/a	200 W	n/a	2	2I
10.0 V	30.0 A	n/a	300 W	n/a	3	3I
12.0 V	8.50 A	n/a	102 W	n/a	2	1J
12.0 V	17.0 A	n/a	204 W	n/a	2	2J
12.0 V	25.0 A	n/a	300 W	n/a	3	3J
12.0 V	62.5 A	n/a	750 W	n/a	4	4J
15.0 V	7.00 A	n/a	105 W	n/a	2	1L
15.0 V	14.0 A	n/a	210 W	n/a	2	2L
15.0 V	20.0 A	n/a	300 W	n/a	3	3L
15.0 V	50.0 A	n/a	750 W	n/a	4	4L
18.0 V	16.7 A	n/a	300 W	n/a	3	3N
24.0 V	5.00 A	n/a	120 W	n/a	2	1P
24.0 V	10.5 A	n/a	252 W	n/a	2	2P
24.0 V	17.0 A	n/a	408 W	n/a	3	3P
24.0 V	31.5 A	n/a	750 W	n/a	4	4P
24.0 V	5.00 A	10.0 A	120 W	240 W	2	1R ⁽¹⁾
24.0 V	10.5 A	21.0 A	252 W	504 W	2	2R ⁽¹⁾
24.0 V	17.0 A	34.0 A	408 W	816 W	3	3R ⁽¹⁾
30.0 V	8.4 A	n/a	252 W	n/a	2	2S
30.0 V	13.5 A	n/a	405 W	n/a	3	3S
28.0 V	4.50 A	n/a	126 W	n/a	2	1Q
28.0 V	9.00 A	n/a	252 W	n/a	2	2Q
28.0 V	14.0 A	n/a	392 W	n/a	3	3Q
28.0 V	26.8 A	n/a	750 W	n/a	4	4Q
36.0 V	3.50 A	n/a	126 W	n/a	2	1U
36.0 V	7.00 A	n/a	252 W	n/a	2	2U
36.0 V	11.0 A	n/a	396 W	n/a	3	3U
36.0 V	21.0 A	n/a	750 W	n/a	4	4U
42.0 V	9.5 A	n/a	400 W	n/a	3	3V
48.0 V	2.50 A	n/a	120 W	n/a	2	1W
48.0 V	5.20 A	n/a	249 W	n/a	2	2W
48.0 V	8.50 A	n/a	408 W	n/a	3	3W
48.0 V	15.7 A	n/a	750 W	n/a	4	4W
60.0 V	2.00 A	n/a	120 W	n/a	2	1Y
60.0 V	4.20 A	n/a	252 W	n/a	2	2Y
60.0 V	7.00 A	n/a	420 W	n/a	3	3Y
60.0 V	12.5 A	n/a	750 W	n/a	4	4Y

1. Peak power available for 10 seconds with 35% duty cycle, if peak power rating is exceeded output may latch, recycle input to reset.

Example

X15-4W4W-120061/4W4W-120000

X15 - 2500 W (230 VAC) industrial chassis, 20 module slots available.

- 4W - 48 V @ 15.7 A Four slot width module top bay.
- 4W - 48 V @ 15.7 A Four slot width module top bay.
- 4W - 48 V @ 15.7 A Four slot width module bottom bay.
- 2W - 48 V @ 5.2 A Two slot width module bottom bay.
- 12 - 4W & 4W top bay in parallel to give 48 V @ 31.4 A.
- 12 - 4W & 2W bottom bay in parallel to give 48 V @ 20.9 A.
- 61 - 4W & 4W top bay in parallel with 4W & 2W bottom bay to give 48 V @ 52.3 A.

Parallel Option Codes	
Code	Description
00	No parallel required
12	Modules 1 & 2
13	Modules 1 to 3
14	Modules 1 to 4
23	Modules 2 & 3
24	Modules 2 to 4
25	Modules 2 to 5
34	Modules 3 & 4
35	Modules 3 to 5
40	Modules 1 & 2, 3 & 4

Series Option Codes	
Code	Description
00	No series required
12	Modules 1 & 2
13	Modules 1 to 3
23	Modules 2 & 3
24	Modules 2 to 4
40	Modules 1 & 2, 3 & 4

Vertical Parallel Option Code	
Code	Description
61	Parallel module 1 top bay to module 1 bottom bay

Other Option Codes	
Code	Description
01	Reverse Air
02	Global Enable - Logic 1
03	Option 01 & 02
04	Global DC OK - Logic 1
05	Option 01 & 04
06	Option 02 & 04
07	Option 01, 02 & 04
08	Global AC OK - Logic 1
09	Option 01 & 08
10	Option 02 & 08
11	Option 01, 02 & 08
12	Option 04 & 08
13	Option 01, 04 & 08
14	Option 02, 04 & 08
15	Option 01, 02, 04 & 08
16	Fan Speed Control
17	Option 01 & 16
18	Option 02 & 16
19	Option 04 & 16
20	Option 08 & 16
21	Option 01, 02 & 16
22	Option 01, 04 & 16
23	Option 01, 08 & 16
24	Option 02, 04 & 16
25	Option 02, 08 & 16
26	Option 04, 08 & 16
27	Option 01, 02, 04 & 16
28	Option 01, 02, 08 & 16
29	Option 02, 04, 08 & 16
30	Option 01, 02, 04, 08 & 16

Note:
1. Fancard options 16-30 will occupy 2 slots. See mechanical drawing.

Signals

Global AC OK/Power Fail

Global AC OK is an isolated transistor of an optocoupler providing a minimum of 5 ms warning of loss of output regulation. The signal is fully isolated and the collector and emitter must be connected externally.
Maximum sink current 2 mA, maximum voltage 20 V.

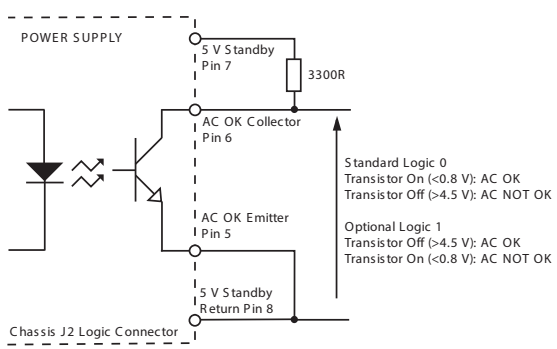

Global DC OK

Global DC OK is an isolated transistor of an optocoupler providing warning that the output voltage has fallen below 90% of nominal. The signal is fully isolated and the collector and emitter must be connected externally.
Maximum sink current 2 mA, maximum voltage 20 V.
On Dual output module, DC OK monitors V1 output only.

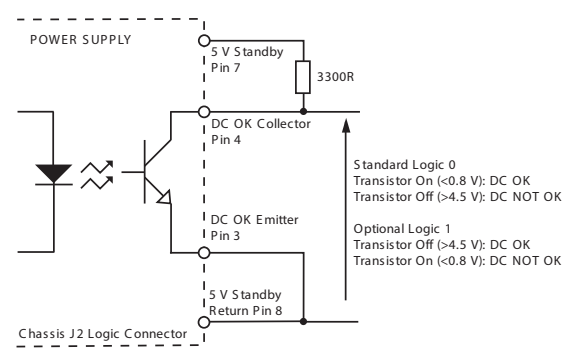

Global Inhibit

Global Inhibit is an isolated control signal input which turns the power supply off by supplying 2 to 5 mA into the pin. Global Enable option available, see 'Other Option Codes' table.

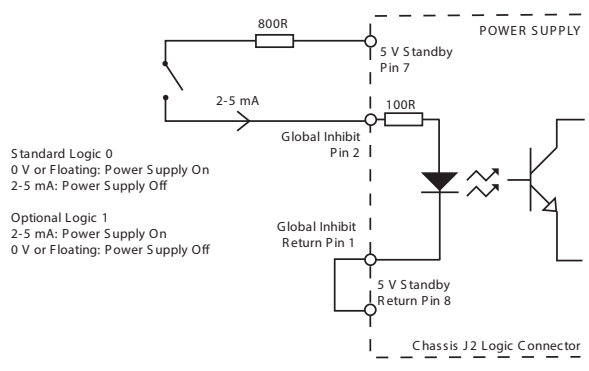

Fan Fail

When fan speed control fitted (option 16).
Open collector signal warns of any fan failure.

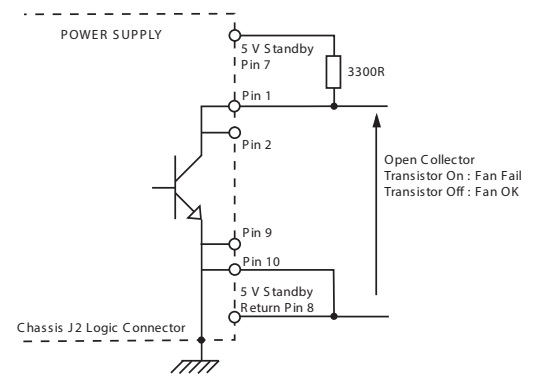

Module DC OK

Module DC OK is a nominal "ON" isolated transistor of an optocoupler which provides a warning of the loss of output regulation on the main output of the module.
Maximum sink current 2 mA, maximum voltage 20 V.

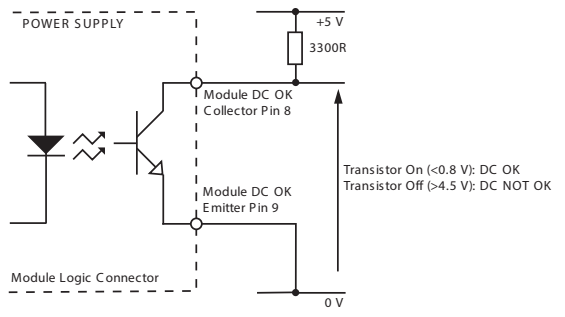

Module Inhibit

Module Inhibit signal is an isolated control signal which turns the module off by supplying 2 to 5 mA into the pin.

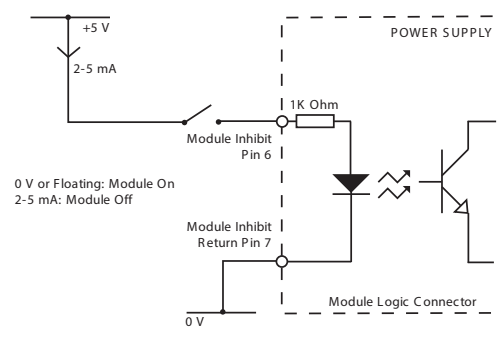

Current Share

Connecting pins 2 and 4 of like voltage modules (4 maximum) within the same chassis or separate chassis will force the current to share between the outputs. Different slot width modules share in proportion to their output current rating.

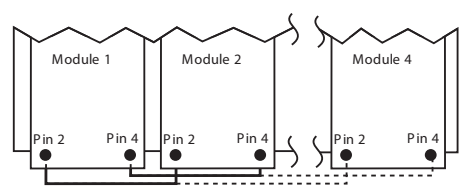

Single Output

2 Slot Modules

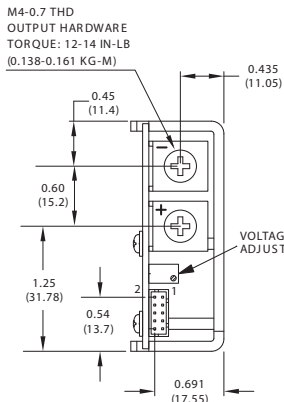

2 Slot Modules (1R / 2R Peak)

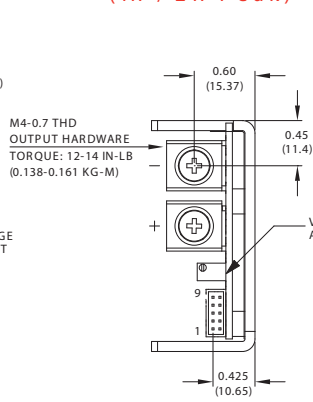

3 Slot Modules (3R Peak)

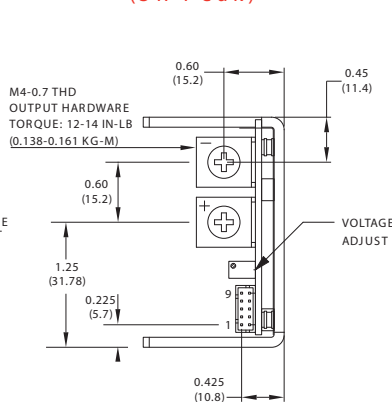

4 Slot Modules

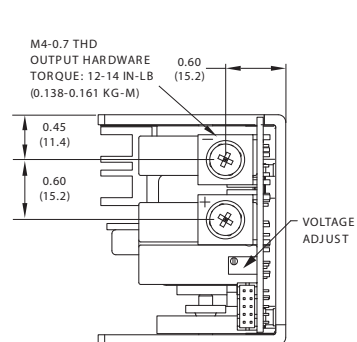

Notes

- All dimensions in inches (mm). Tolerance: .xx = ±0.02 (±0.50); .xxx = ±0.01 (±0.25)
- Weight: 2/2R Slot: 0.48 lb (218 g) approx, 3 Slot: 0.74 lb (335 g) approx, 4 Slot: 0.95 lb (431 g) approx.
- Mating plug: JST part no. PHDR-10VS.
- Contact: 26-22 AWG JST part no. SPHD-001T-P0.5.
- Connector kit available order part no. fleXPower CONKIT.

Single Output: Module Logic Connector Pinouts			
Pin	Function	Pin	Function
1	Sense +	6	Inhibit
2	Sense -	7	Module Inhibit Return
3	V Prog	8	DC OK Collector
4	I Share	9	DC OK Emitter
5	Not used	10	Not used

Dual Output

2 Slot Modules

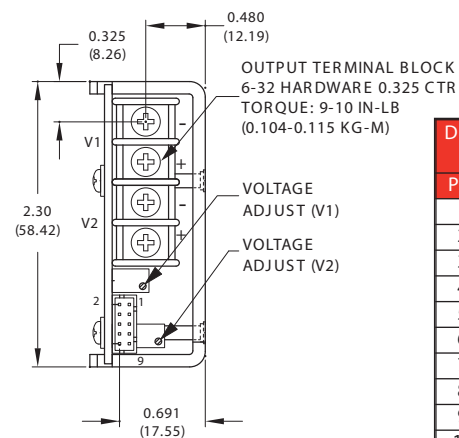

Dual Output: Module Logic Connector Pinouts	
Pin	Function
1	V1 Sense +
2	V1 Sense -
3	Not used
4	Not used
5	V2 Sense +
6	Inhibit
7	Module Inhibit Return
8	DC OK Collector
9	DC OK Emitter
10	V2 Sense -

Notes

- All dimensions in inches (mm). Tolerance: .xx = ±0.02 (±0.50); .xxx = ±0.01 (±0.25)
- Weight: 0.48 lb (218 g) approx.
- Mating plug: JST part no. PHDR-10VS.
- Contact: 26-22 AWG JST part no. SPHD-001T-P0.5.
- Connector kit available order part no. fleXPower CONKIT.

Fan Speed Control Module

2 Slot Module

Controls speed of fan(s) depending on output load and thermal environment of the power supply. Also provides warning of any fan failure.

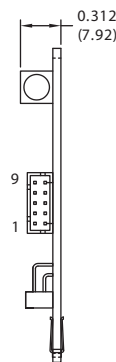

Fan Speed Control Module Connector Pinouts	
Pin	Function
1	Fan Fail
2	Fan Fail
3	Not Used
4	Not Used
5	Not Used
6	Not Used
7	Not Used
8	Not Used
9	Ground
10	Ground

Notes

- All dimensions in inches (mm). Tolerance: .xx = ±0.02 (±0.50); .xxx = ±0.01 (±0.25)
- Weight: 0.10 lb (45 g) approx.
- Mating plug: JST part no. PHDR-10VS.
- Contact: 26-22 AWG JST part no. SPHD-001T-P0.5.
- Connector kit available order part no. fleXPower CONKIT.

Chassis Mechanical Details

400 (600)⁽⁴⁾ Watt X4 & XM4 Chassis, 500 (700)⁽⁴⁾ Watt X5 & XM5 Chassis, 700 (900)⁽⁴⁾ Watt X7 & XM7 Chassis

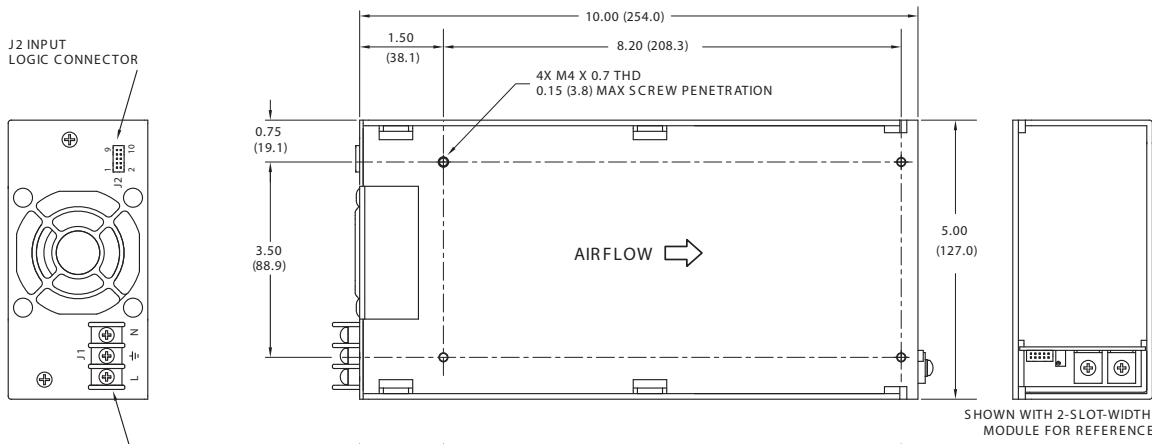

J2 INPUT LOGIC CONNECTOR

AC INPUT TERMINAL BLOCK M3.5 HARDWARE, 0.375 (9.52) CENTERS TORQUE: 9-10 IN-LB (0.104-0.115 KG-M)

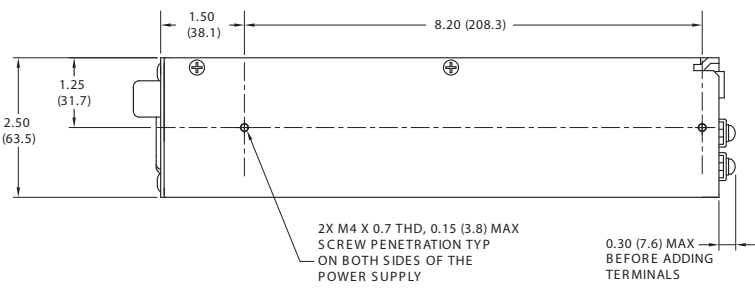

J2 Input Logic Connector Pinouts	
Pin	Function
1	Global Inhibit Return
2	Global Inhibit
3	Global DC OK Emitter
4	Global DC OK Collector
5	Global AC OK Emitter
6	Global AC OK Collector
7	5V Standby
8	5V Standby Return
9	Manufacturer Use Only
10	Manufacturer Use Only

900 (1100)⁽⁴⁾ Watt X9 & XM9 Chassis

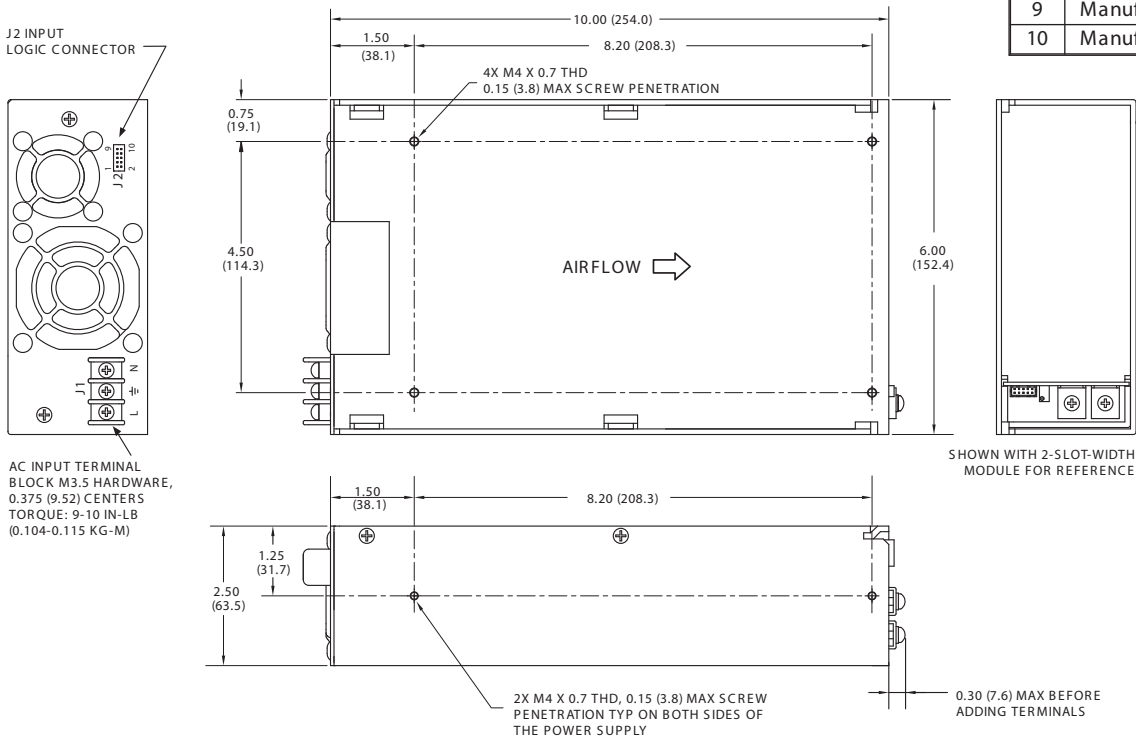

J2 INPUT LOGIC CONNECTOR

AC INPUT TERMINAL BLOCK M3.5 HARDWARE, 0.375 (9.52) CENTERS TORQUE: 9-10 IN-LB (0.104-0.115 KG-M)

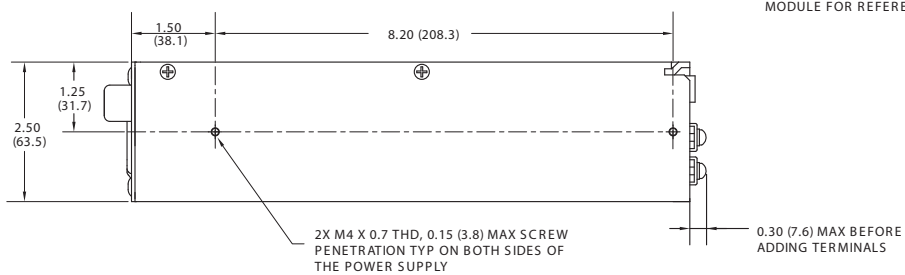

Notes

- All dimensions in inches (mm).
Tolerance X.XX = ±0.02 (0.05), X.XXX = ±0.01 (0.25)
- Mating plug: JST p/n PHDR-10VS.
- Contact: 26-22 AWG JST p/n SPHD-001T-P0.5.
- High line only (180-264 VAC).
- Weights: 400 (600) W X4 & XM4 chassis: 2.75 lbs (1250 g) approx.
500 (700) W X5 & XM5 chassis: 2.75 lbs (1250 g) approx.
700 (900) W X7 & XM7 chassis: 2.75 lbs (1250 g) approx.
900 (1100) W X9 & XM9 chassis: 3.3 lbs (1500 g) approx.

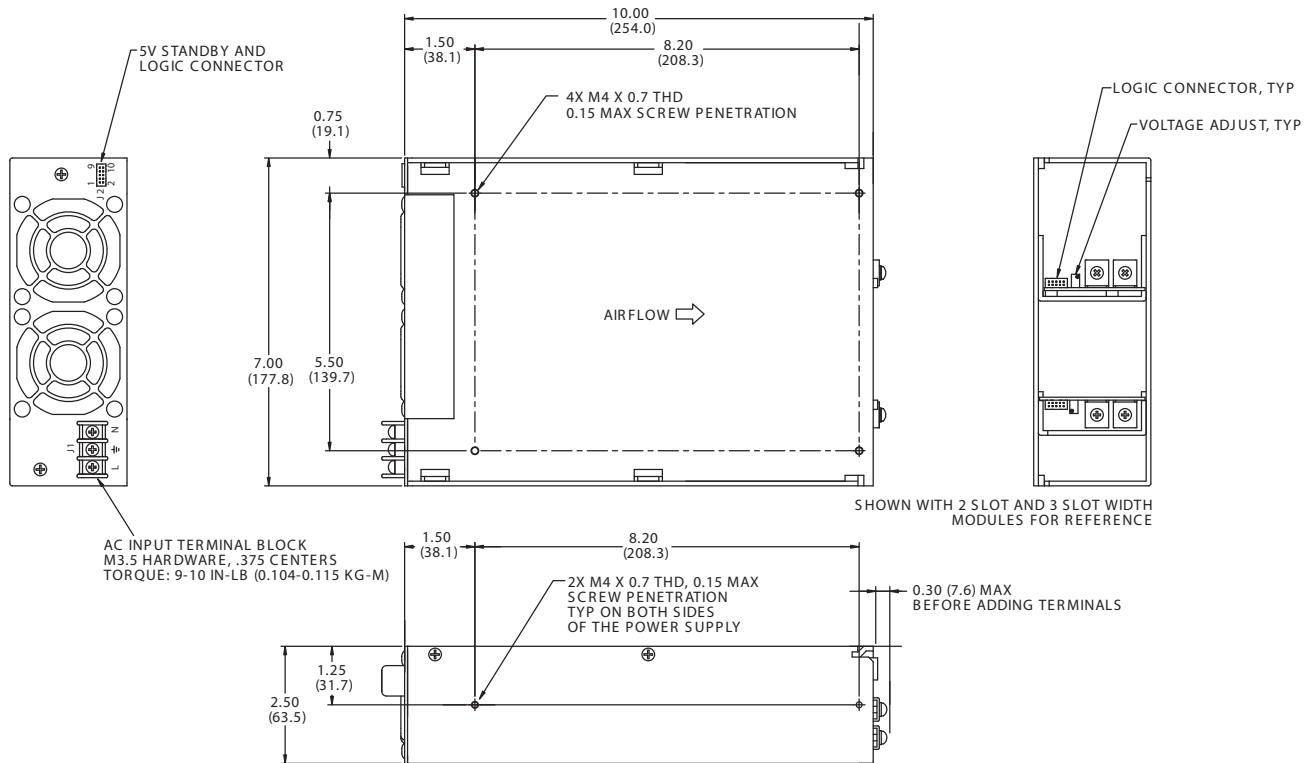
1000 (1200) ⁽⁴⁾ Watt X10 & XM10 Chassis

J2 Input Logic Connector Pinouts

Pin	Function
1	Global Inhibit Return
2	Global Inhibit
3	Global DC OK Emitter
4	Global DC OK Collector
5	Global AC OK Emitter
6	Global AC OK Collector
7	5V Standby
8	5V Standby Return
9	Manufacturer Use Only
10	Manufacturer Use Only

Notes

- All dimensions in inches (mm). Tolerance X.XX = ± 0.02 (0.05), X.XXX = ± 0.01 (0.25)
- Mating plug: JST p/n PHDR-10VS.
- Contact: 26-22 AWG JST p/n SPHD-001T-P0.5.
- High line only (180-264 VAC).
- Weight: 4 lbs (1800 g) approx.

Chassis Mechanical Details

800 (1200)⁽⁴⁾ Watt X4DD & XM4DD Chassis, 1000 (1400)⁽⁴⁾ Watt X5DD & XM5DD Chassis
 1400 (1800)⁽⁴⁾ Watt X7DD & XM7DD Chassis

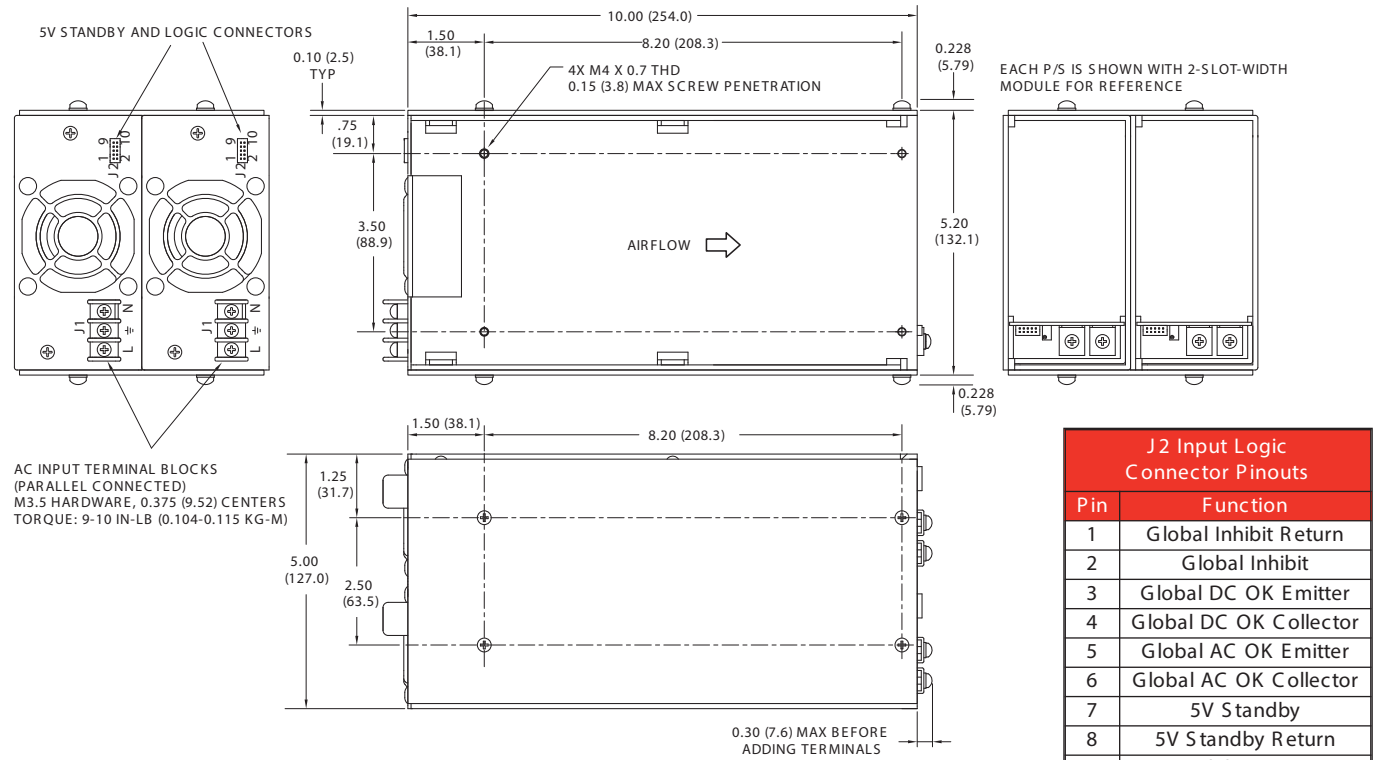

J2 Input Logic Connector Pinouts	
Pin	Function
1	Global Inhibit Return
2	Global Inhibit
3	Global DC OK Emitter
4	Global DC OK Collector
5	Global AC OK Emitter
6	Global AC OK Collector
7	5V Standby
8	5V Standby Return
9	Inhibit Sum
10	VCC Return

1800 (2200)⁽⁴⁾ Watt X9DD & XM9DD Chassis

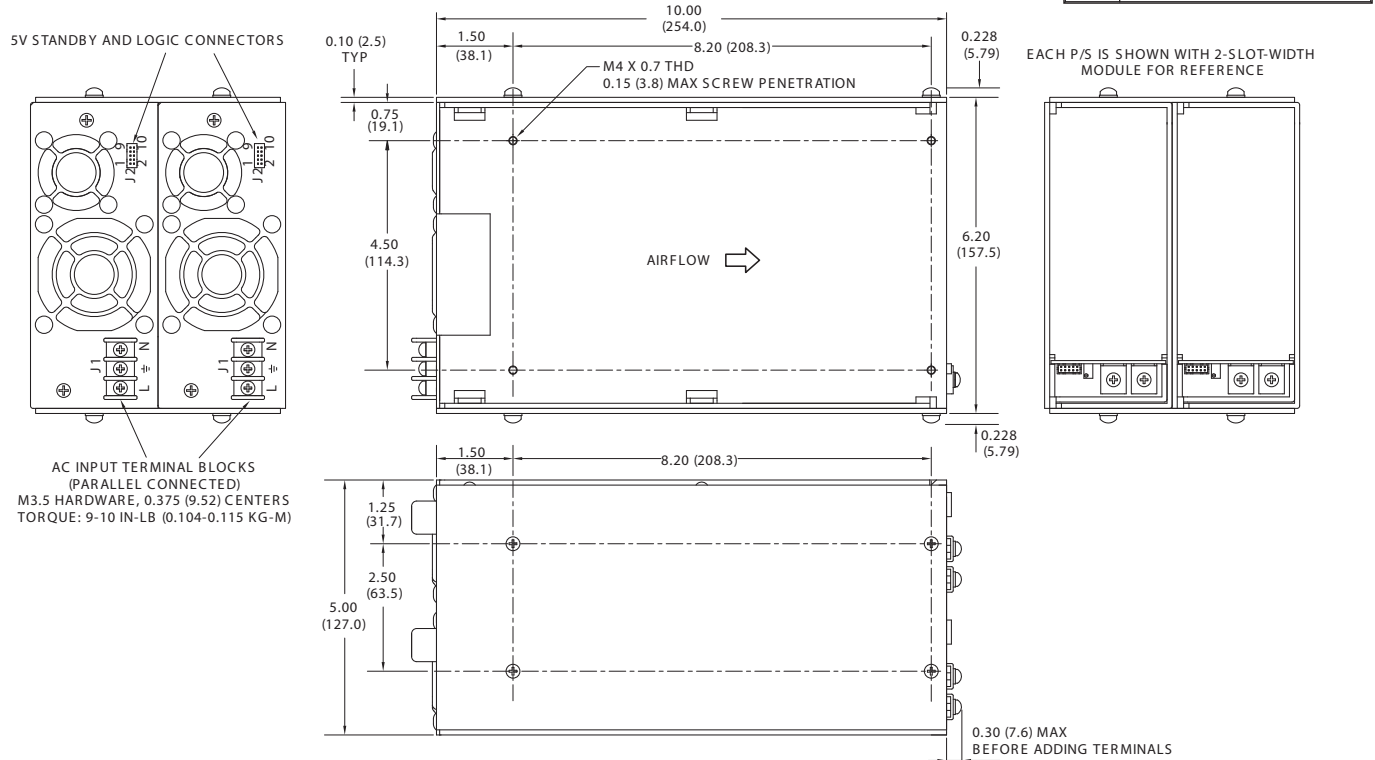

Notes

- All dimensions in inches (mm).
Tolerance X.XX = ±0.02 (0.05), X.XXX = ±0.01 (0.25)
- Mating plug: JST p/n PHDR-10VS.
- Contact: 26-22 AWG JST p/n SPHD-001T-P0.5.
- High line only (180-264 VAC).
- Weights: 800 (1200) W X4DD & XM4DD chassis: 5.5 lbs (2500 g) approx.
1000 (1400) W X5DD & XM5DD chassis: 5.5 lbs (2500 g) approx.
1400 (1800) W X7DD & XM7DD chassis: 5.5 lbs (2500 g) approx.
1800 (2200) W X9DD & XM9DD chassis: 6.6 lbs (3000 g) approx.

2000 (2400)⁽⁴⁾ Watt X10DD & XM10DD Chassis

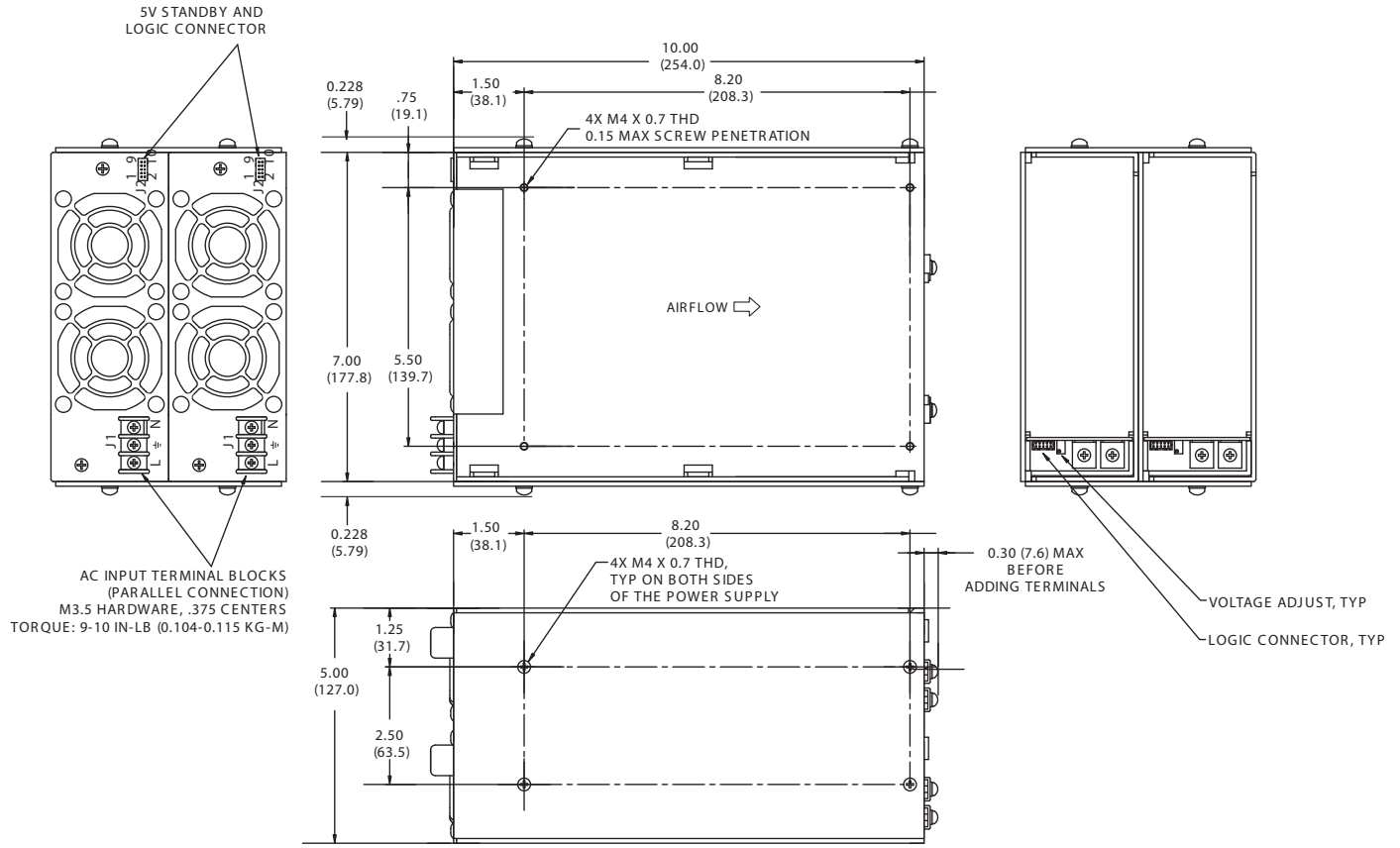

J2 Input Logic Connector Pinouts	
Pin	Function
1	Global Inhibit Return
2	Global Inhibit
3	Global DC OK Emitter
4	Global DC OK Collector
5	Global AC OK Emitter
6	Global AC OK Collector
7	5V Standby
8	5V Standby Return
9	Inhibit Sum
10	VCC Return

Notes

- All dimensions in inches (mm).
Tolerance X.XX = ±0.02 (0.05), X.XXX = ±0.01 (0.25)
- Mating plug: JST p/n PHDR-10VS.
- Contact: 26-22 AWG JST p/n SPHD-001T-P0.5.
- High line only (180-264 VAC).
- Weight: 8.0 lbs (3636 g) approx.

1500 (2500)⁽⁴⁾ Watt X15 & XM15 Chassis

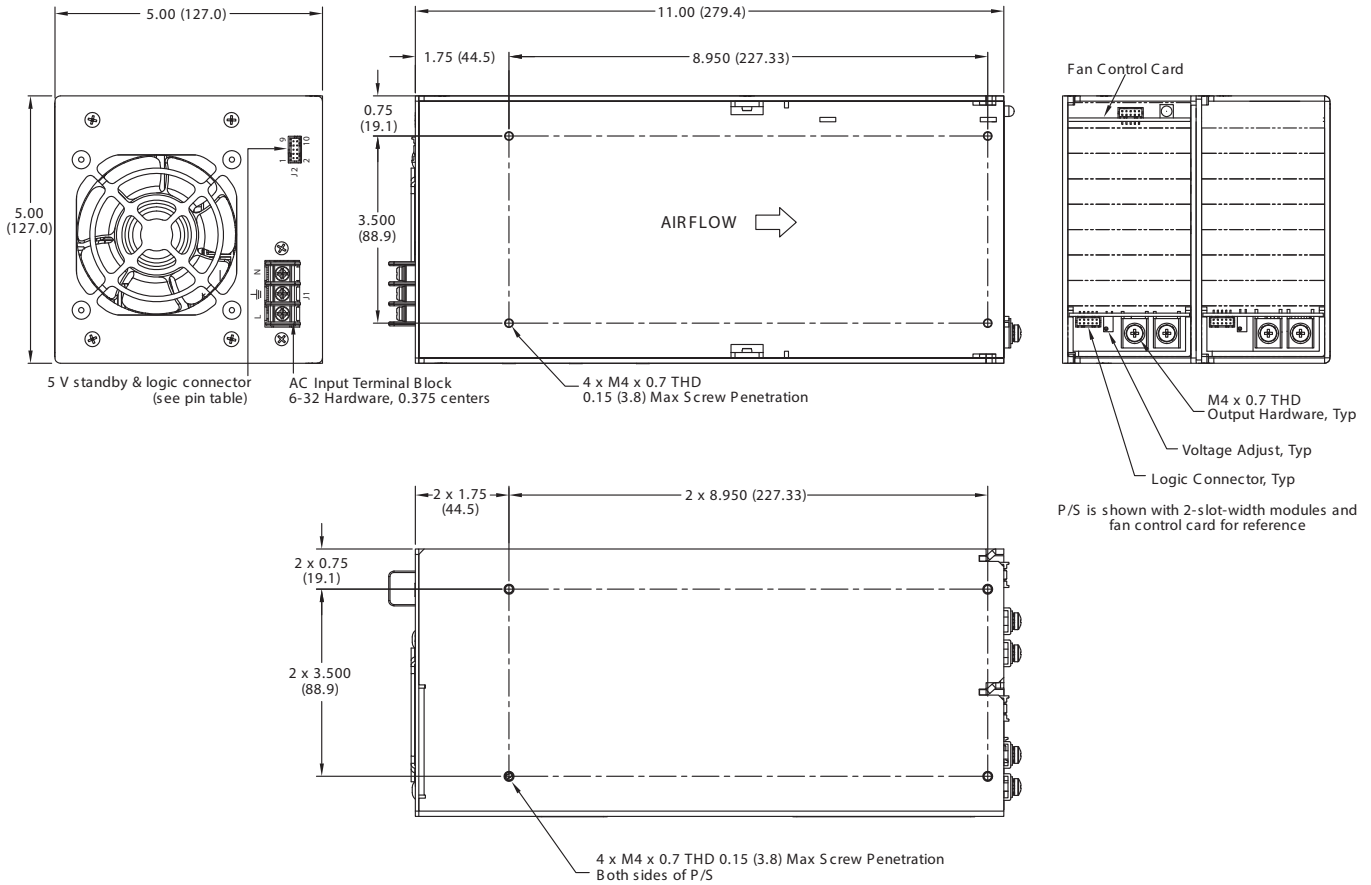

J2 Input Logic Connector Pinouts	
Pin	Function
1	Global Inhibit Return
2	Global Inhibit
3	Global DC OK Emitter
4	Global DC OK Collector
5	Global AC OK Emitter
6	Global AC OK Collector
7	5V Standby
8	5V Standby Return
9	Inhibit Sum (Internal Use Only)
10	VCC Return (Internal Use Only)

Notes

- All dimensions in inches (mm).
Tolerance X.XX = ±0.02 (0.05), X.XXX = ±0.01 (0.25)
- Mating plug: JST p/n PHDR-10VS.
- Contact: 26-22 AWG JST p/n SPHD-001T-P0.5.
- High line only (180-264 VAC).
- Weight: 8.0 lbs (3636 g) approx.